



MINECRAFT



21118





LEGO.com/brickseparator

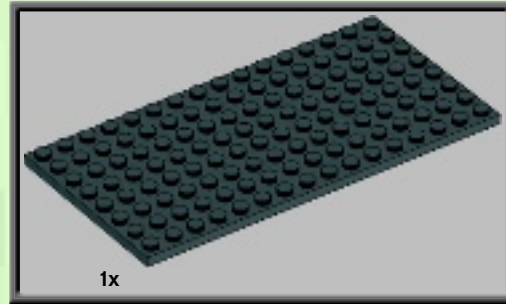
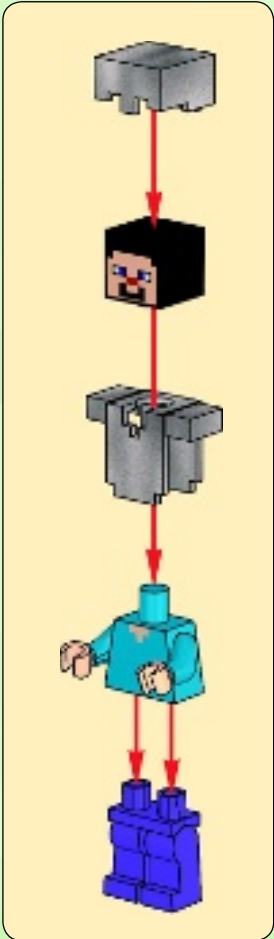
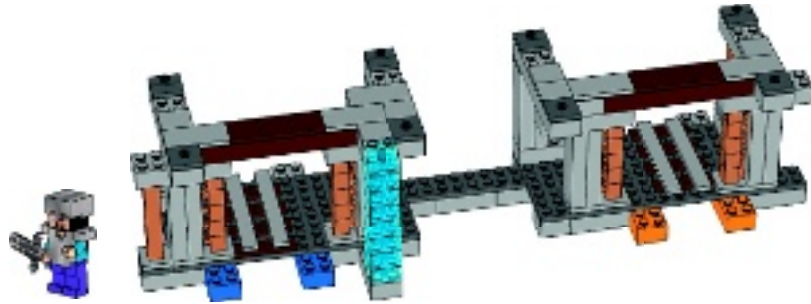

1





2

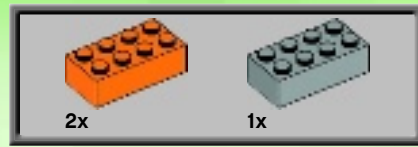
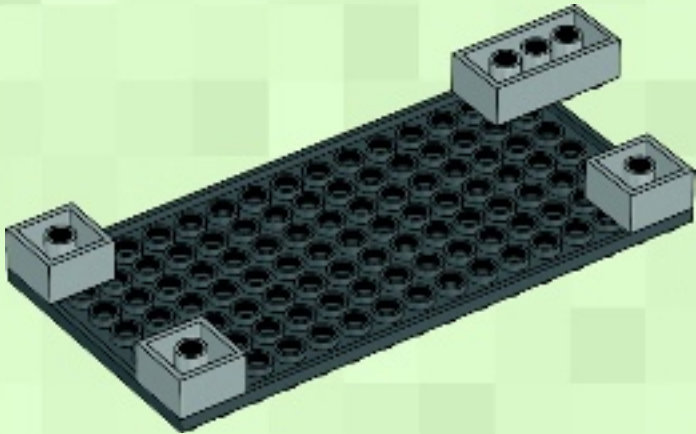

3

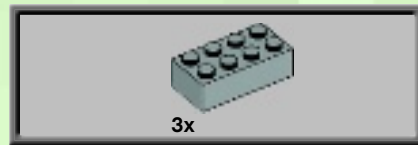
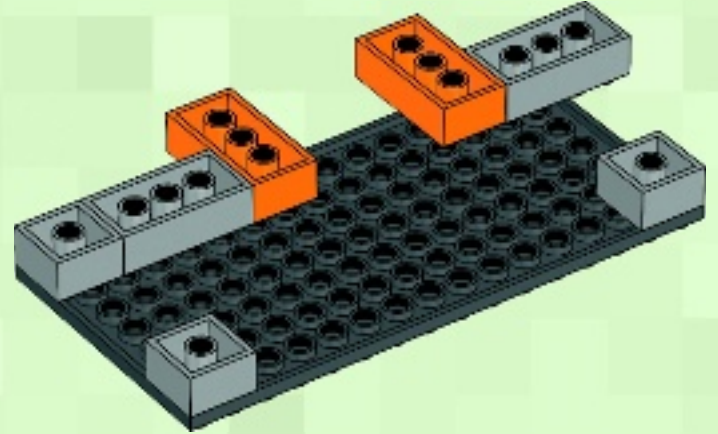

4

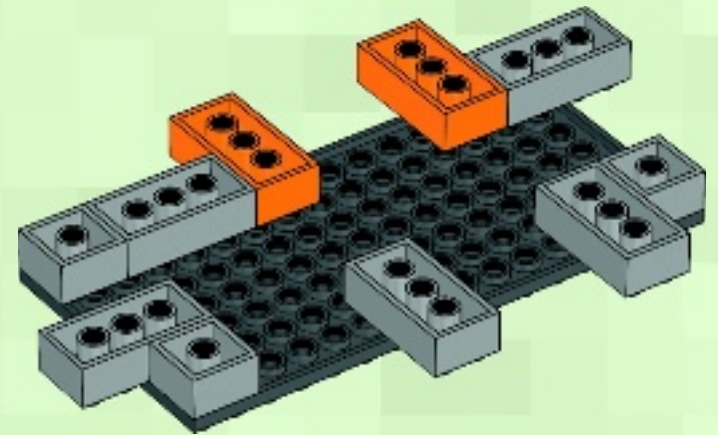

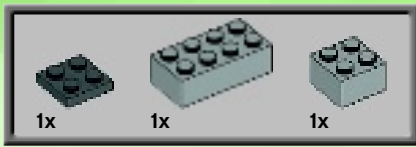

5

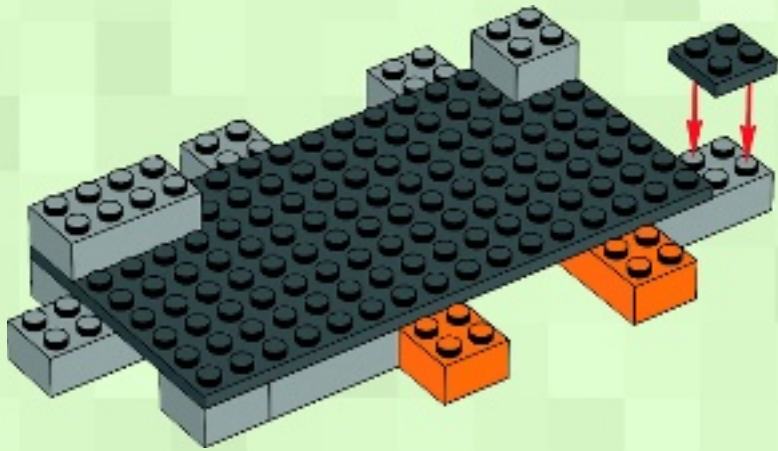
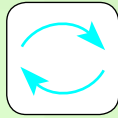

6

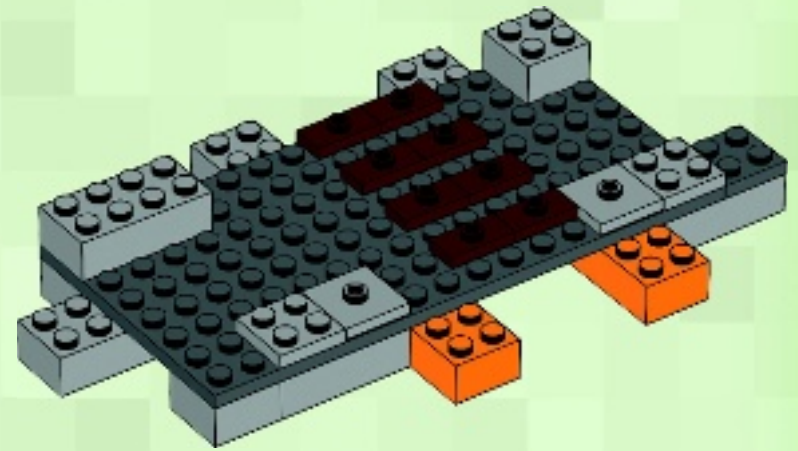

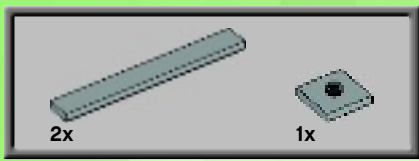

7

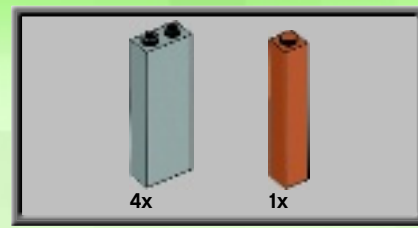
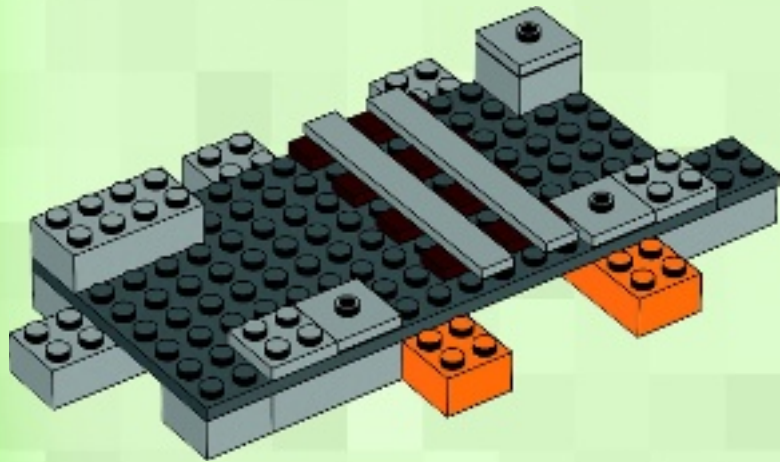

8

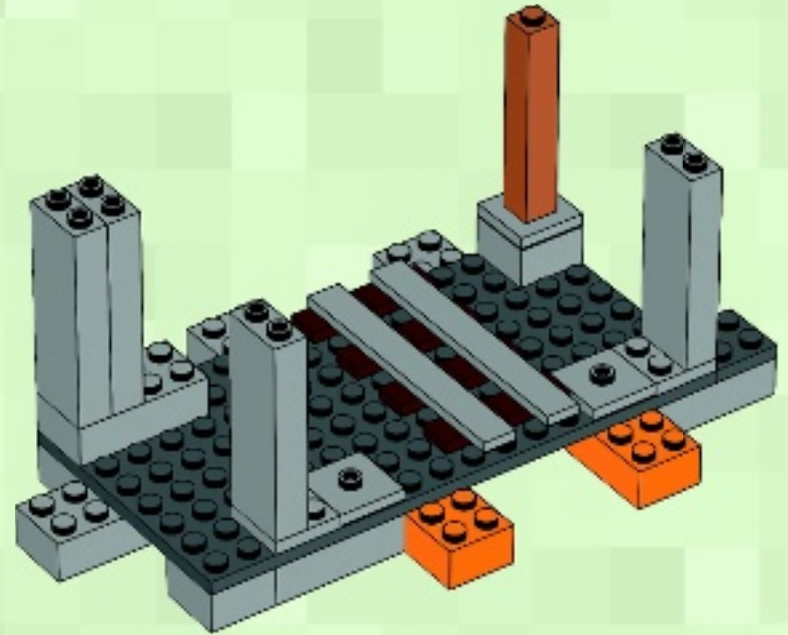

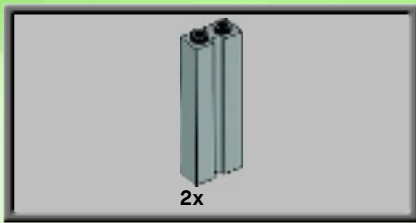

9

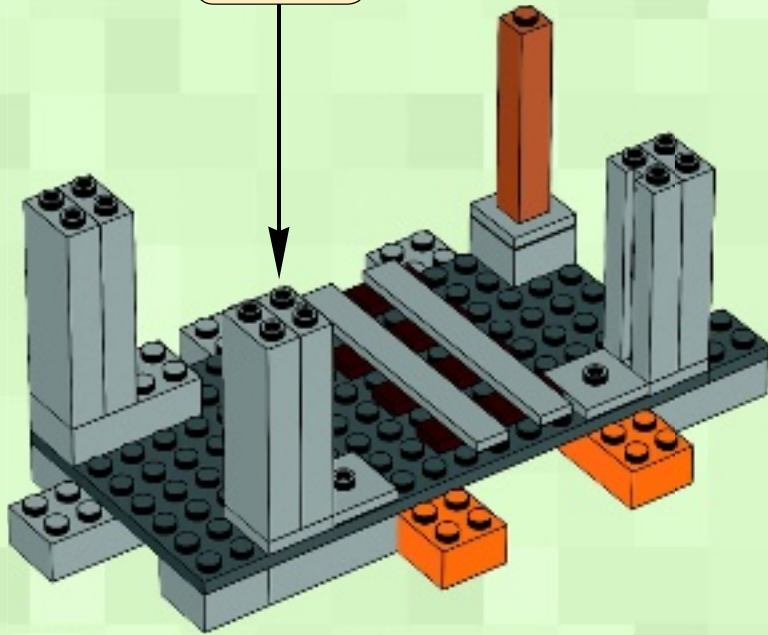
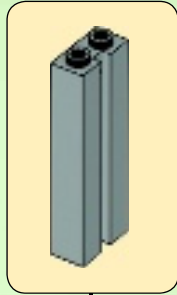

10

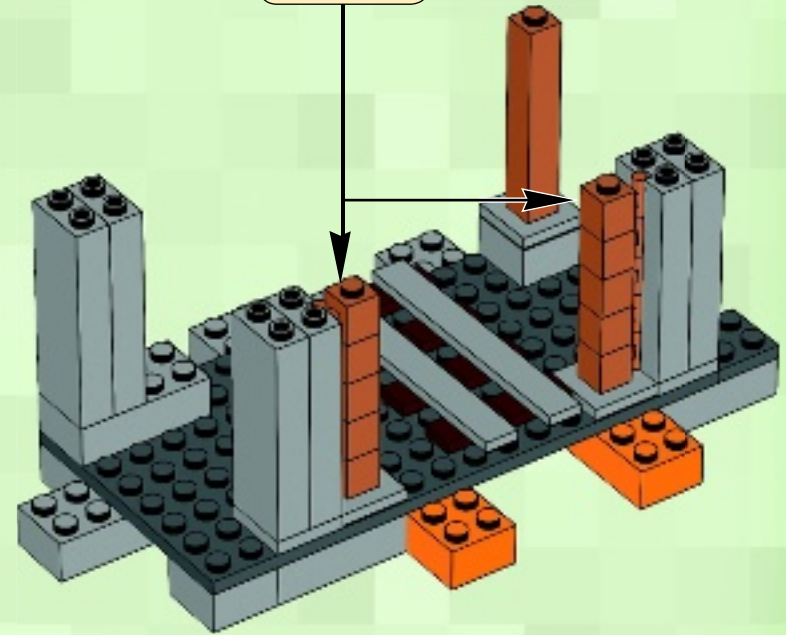
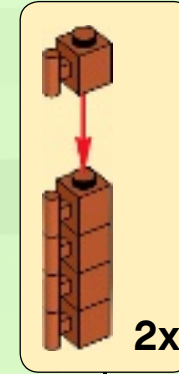

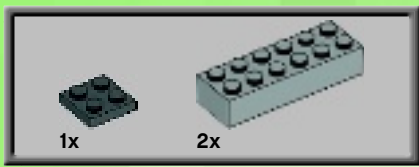

11

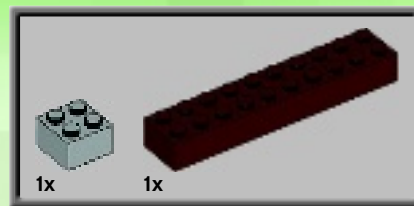
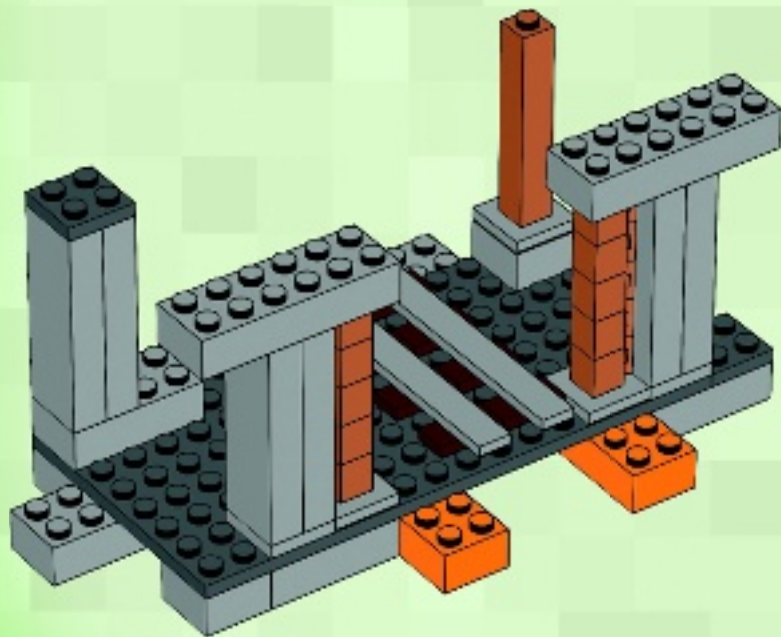

12

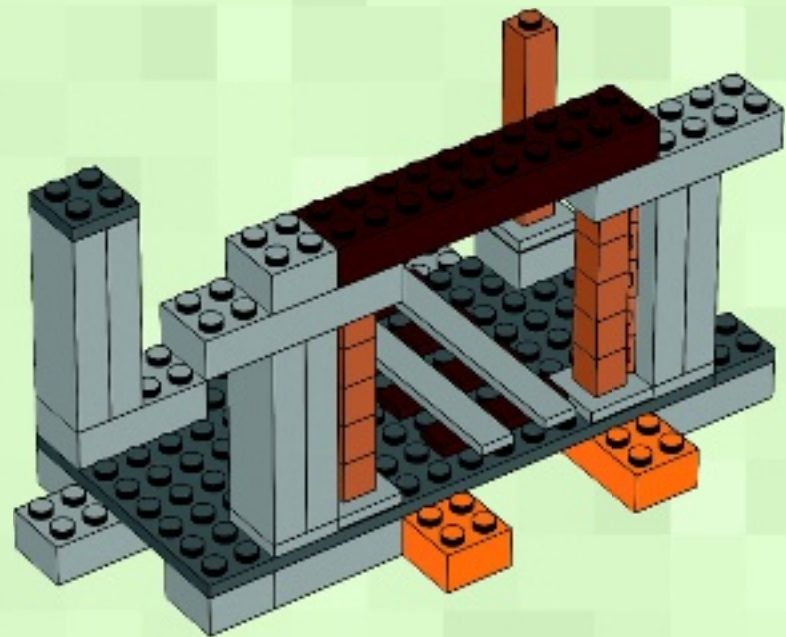

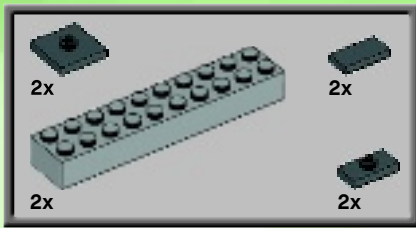

13

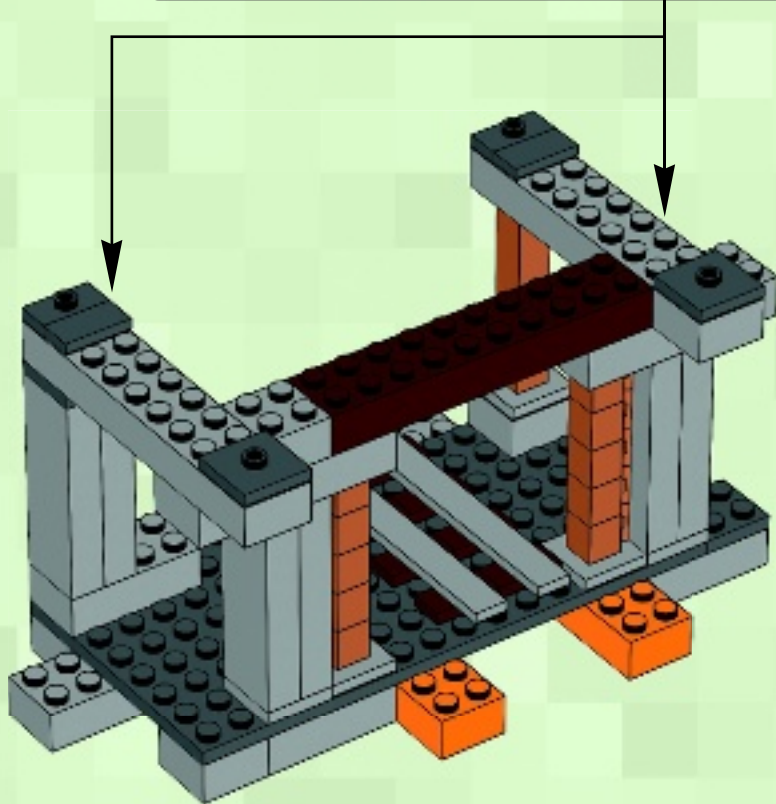
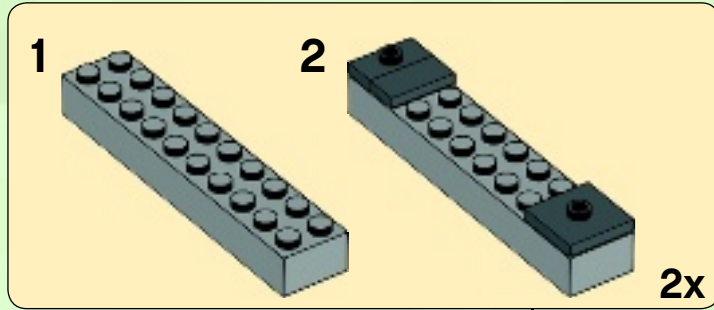

14

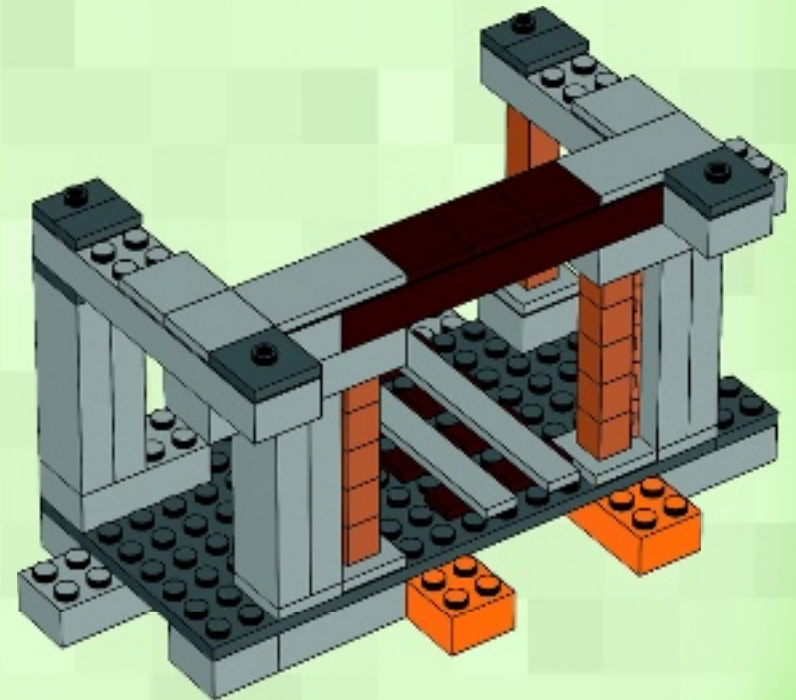

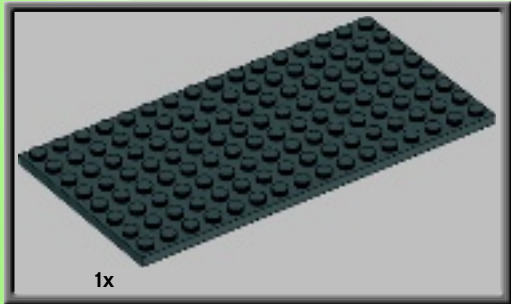
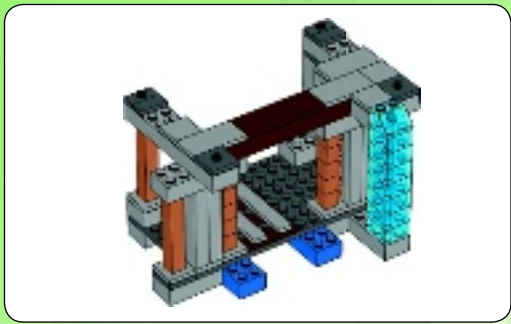

1

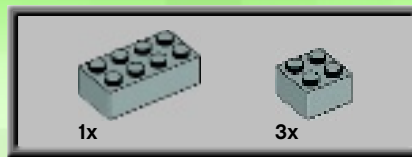
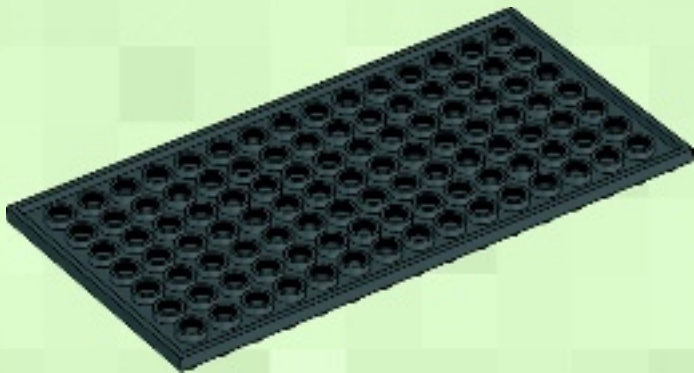

2

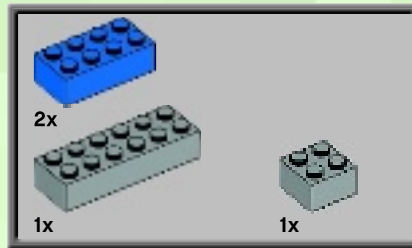
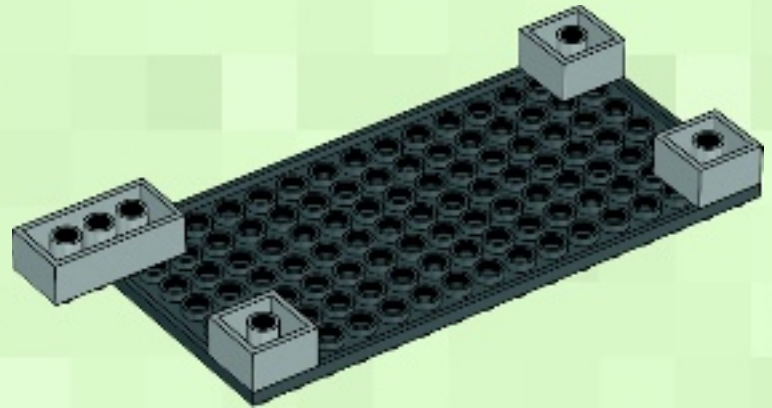

3

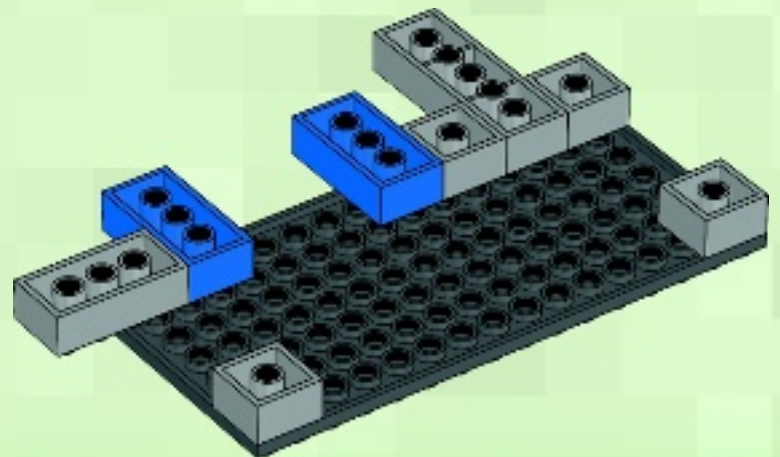

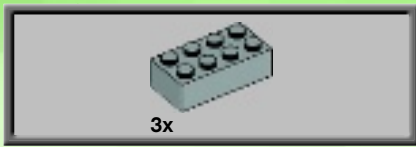

4

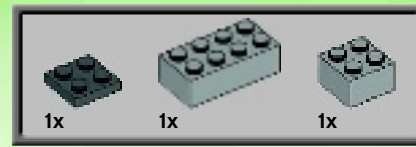
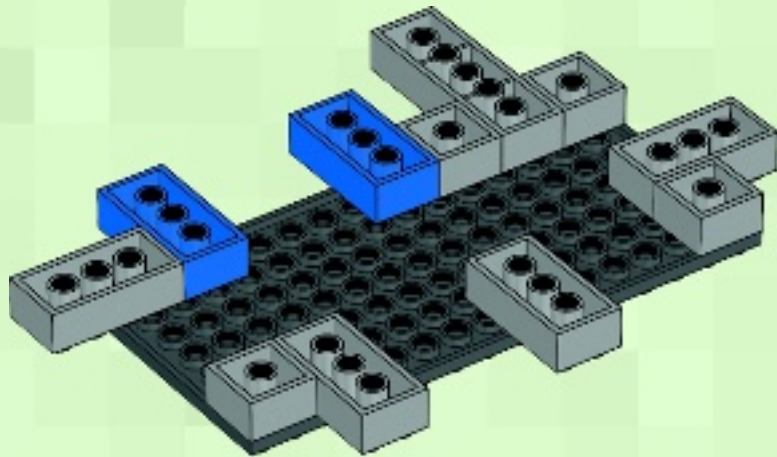

5

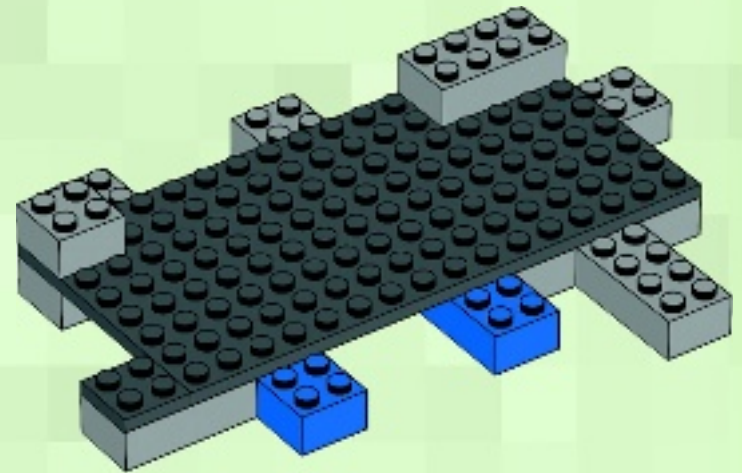
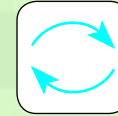



6

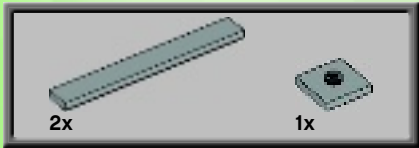
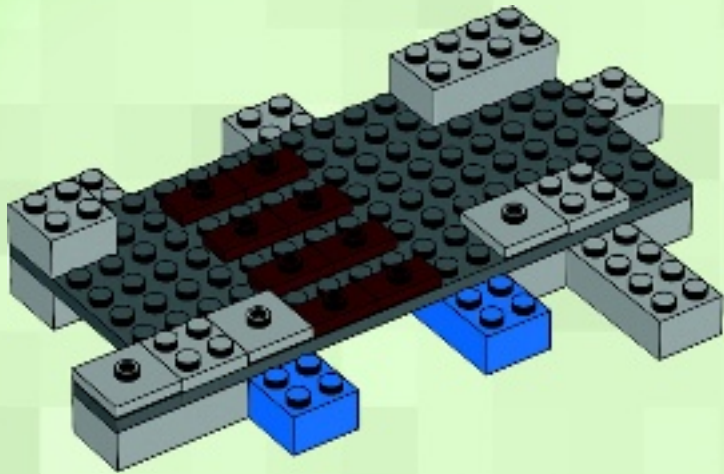

7

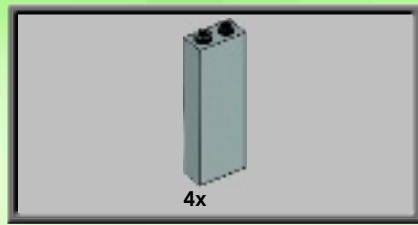
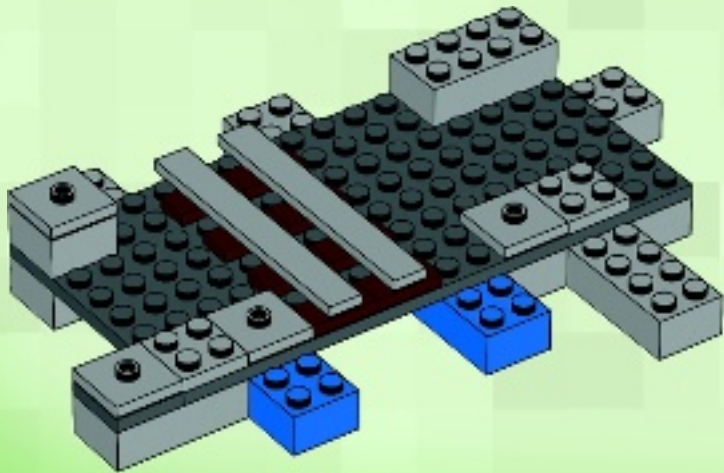

8

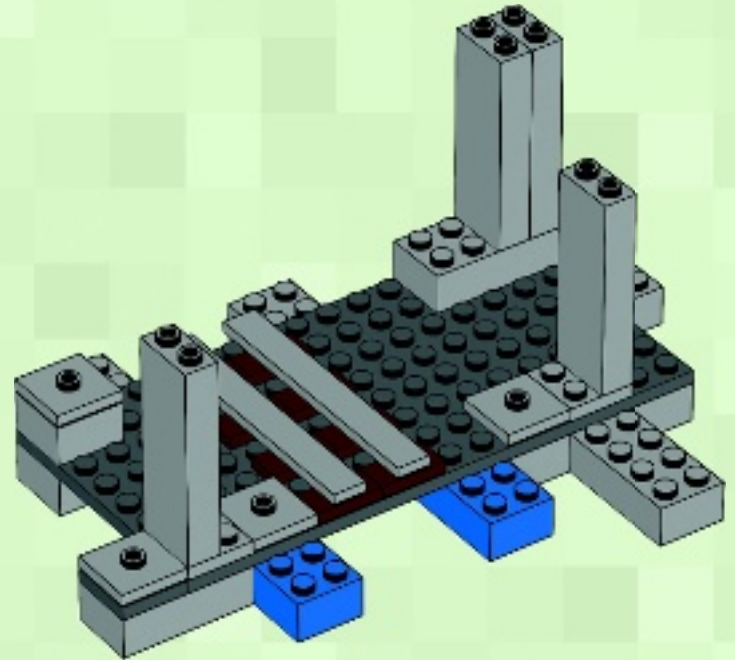

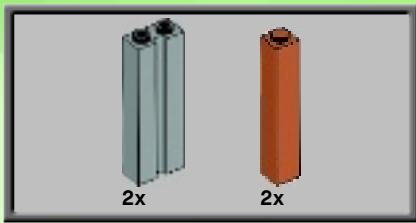

9

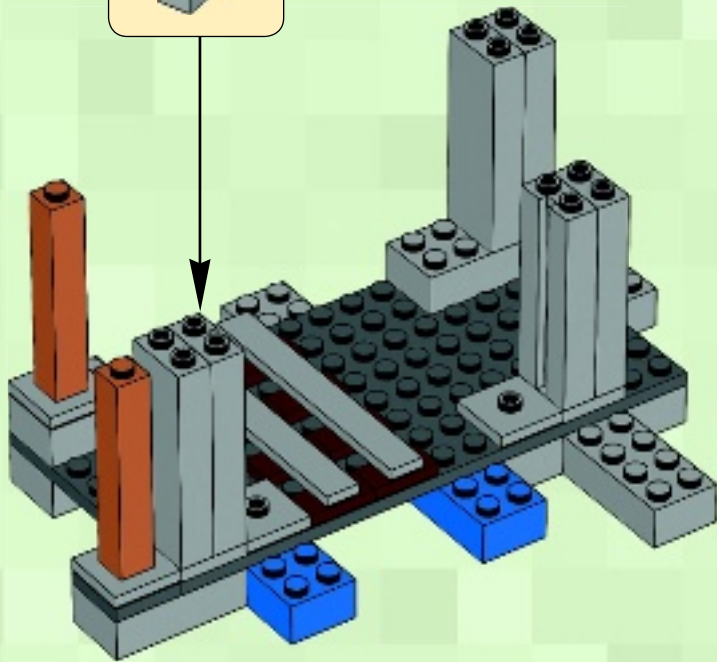
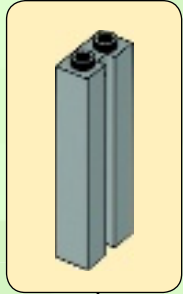

10

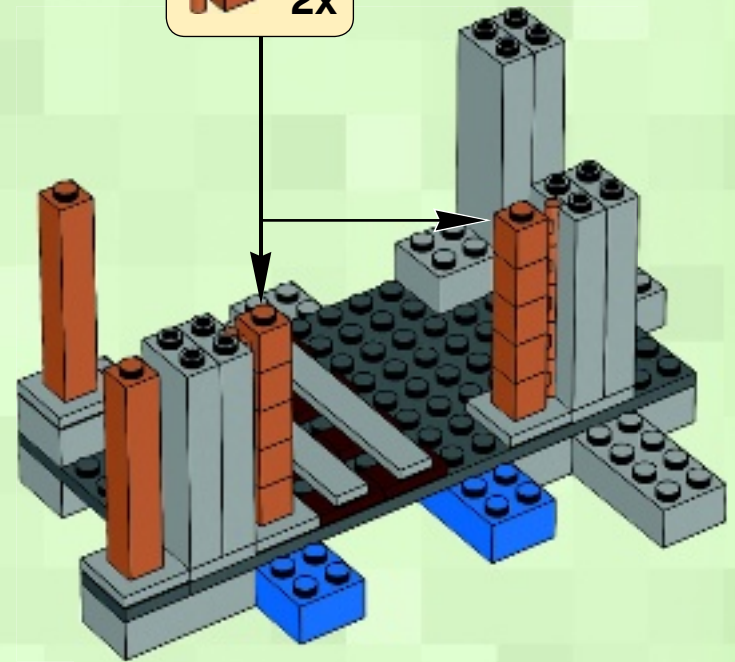
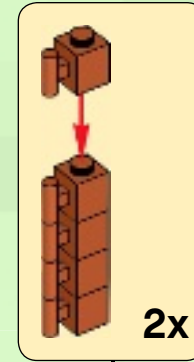

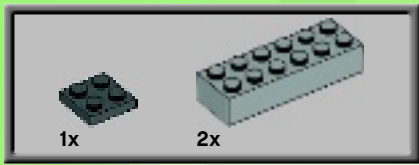

11

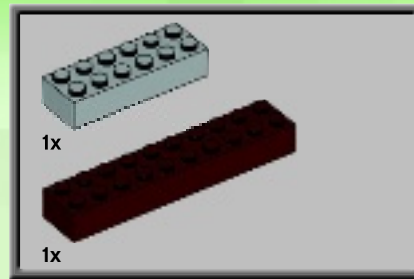
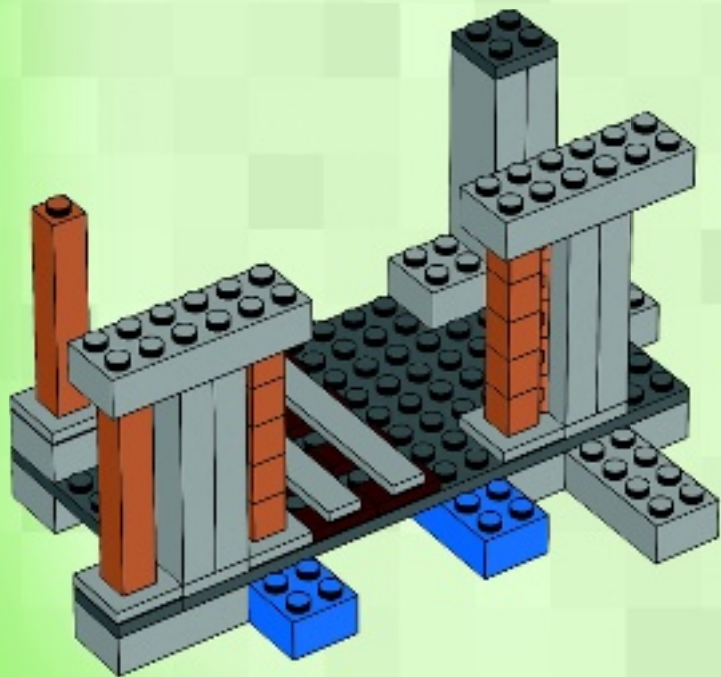

12

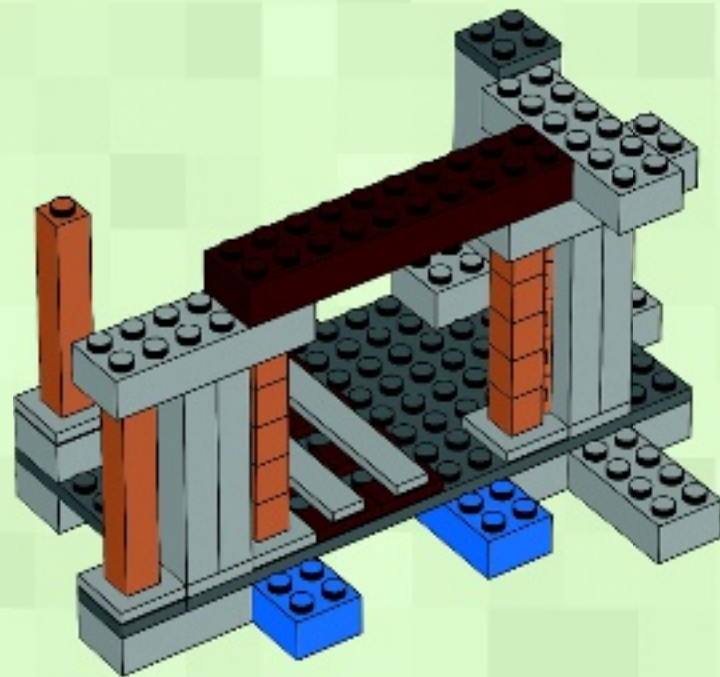

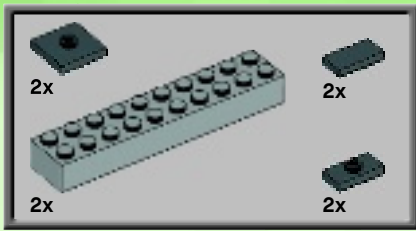

13

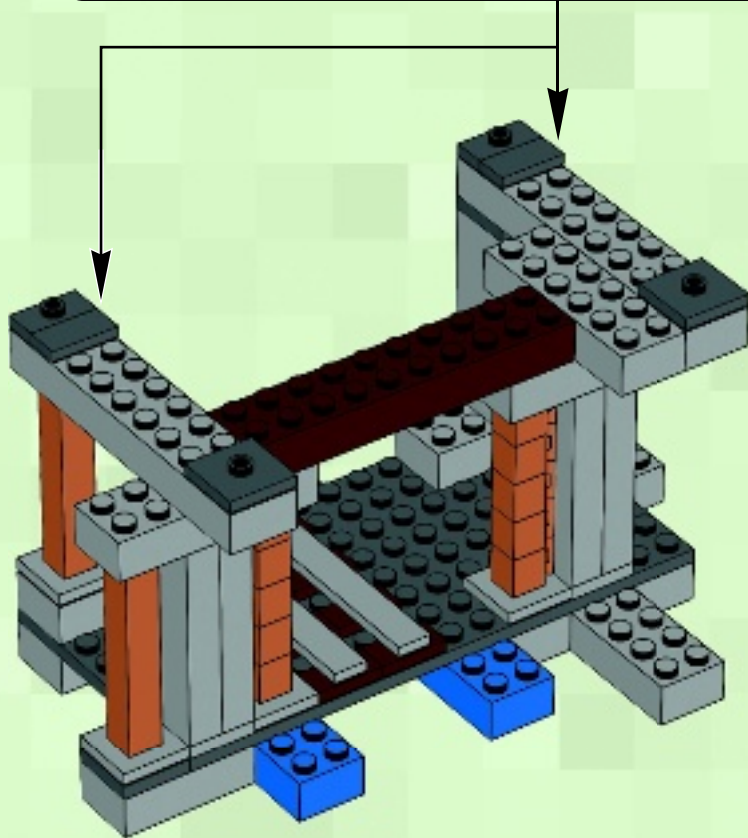
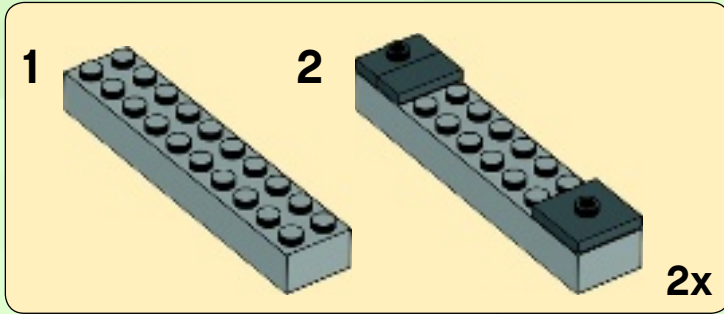

14

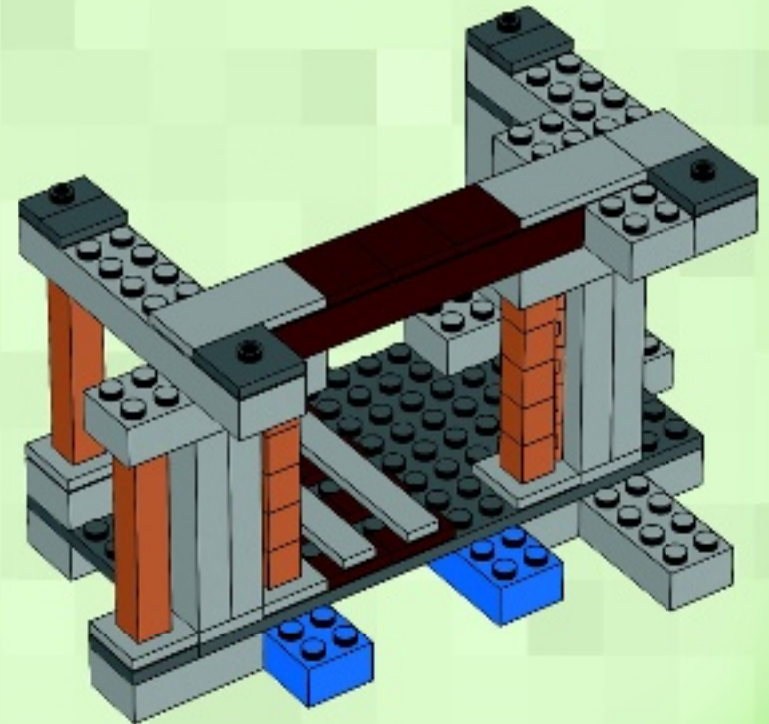

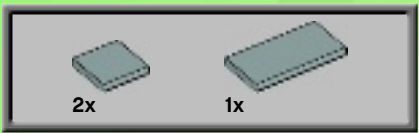

15

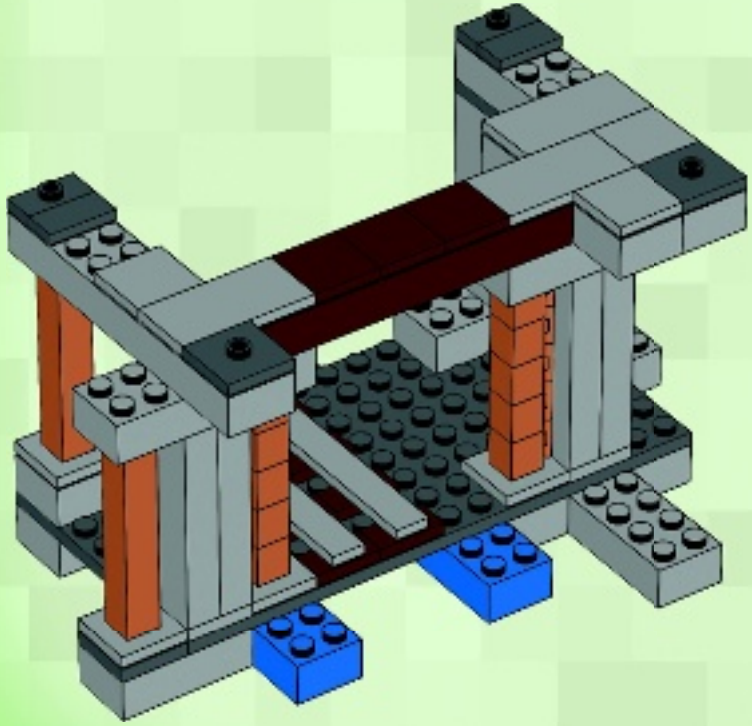

16

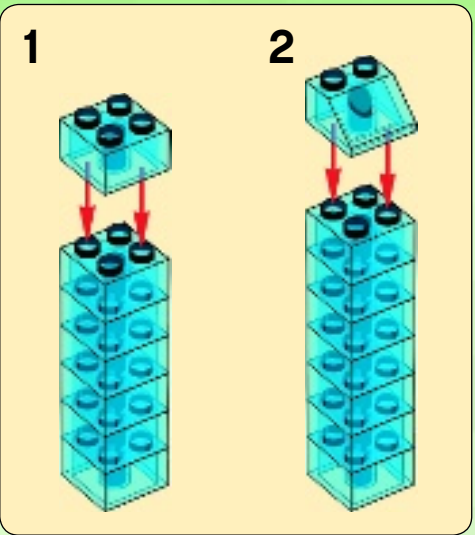
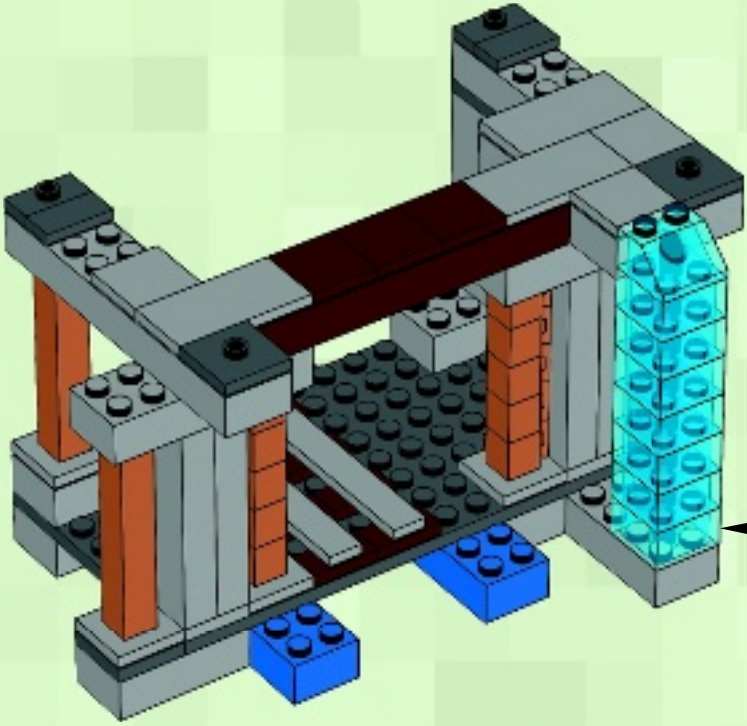

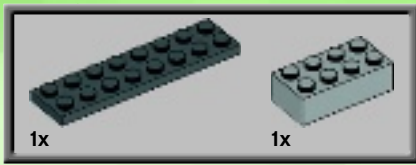

17

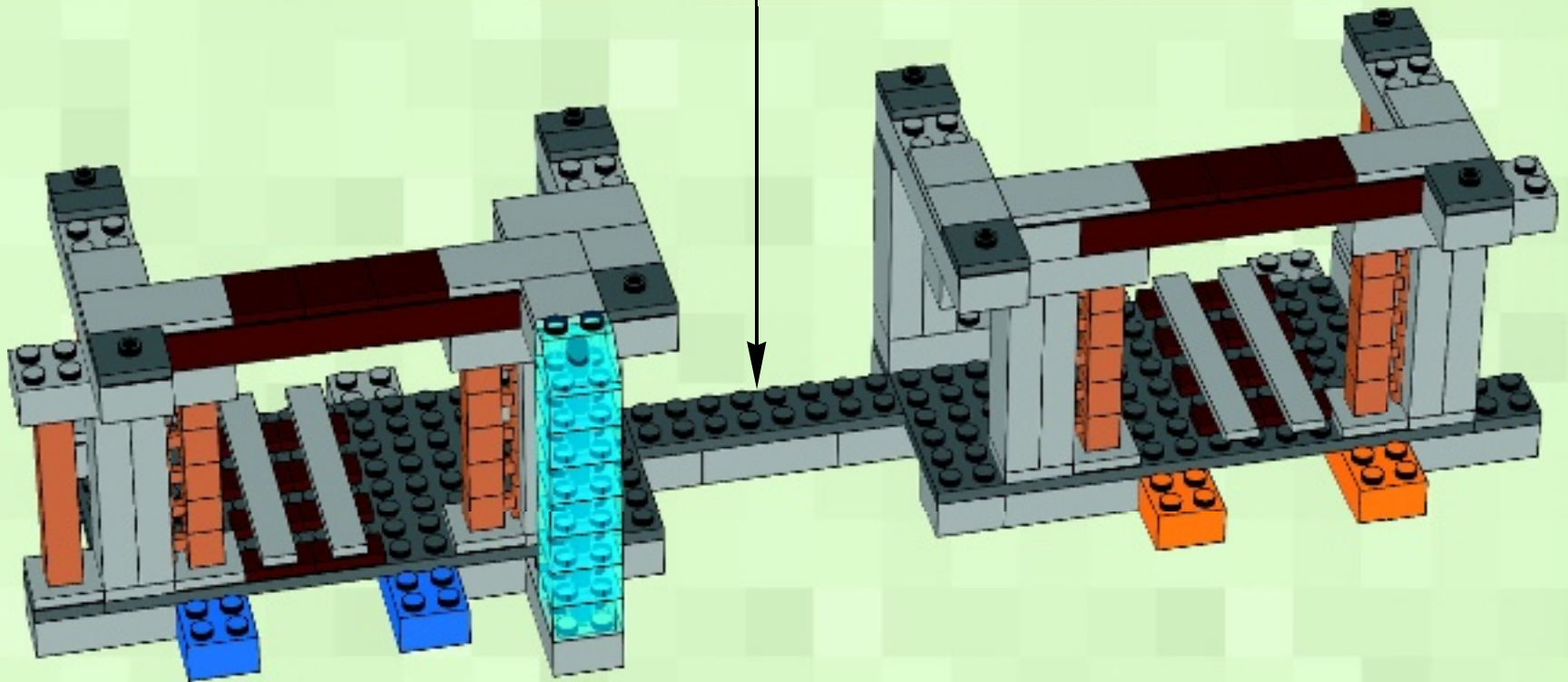
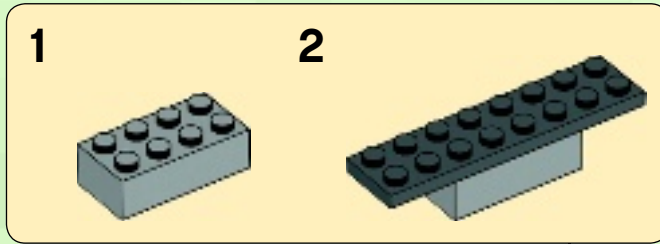

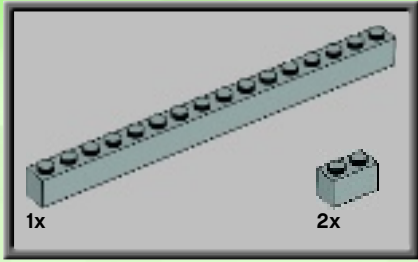
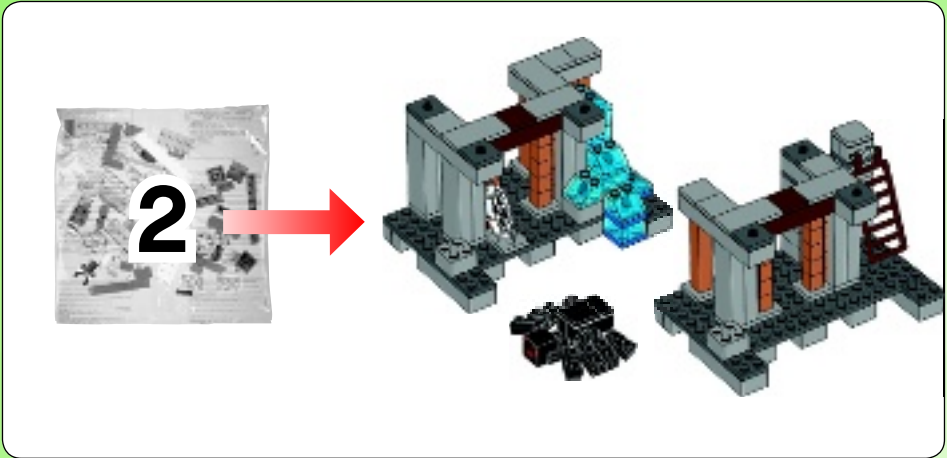

2

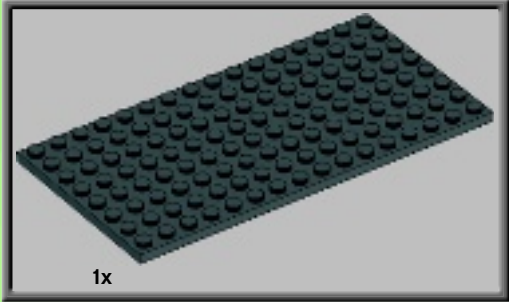

1



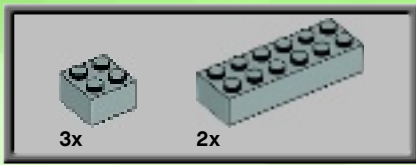

3

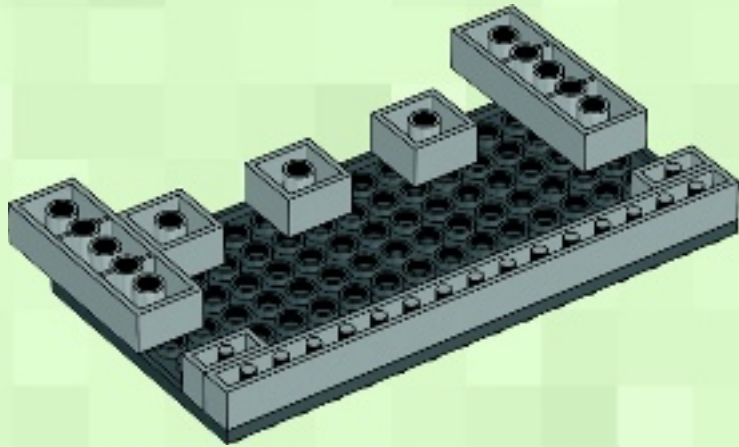

4

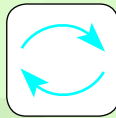

5

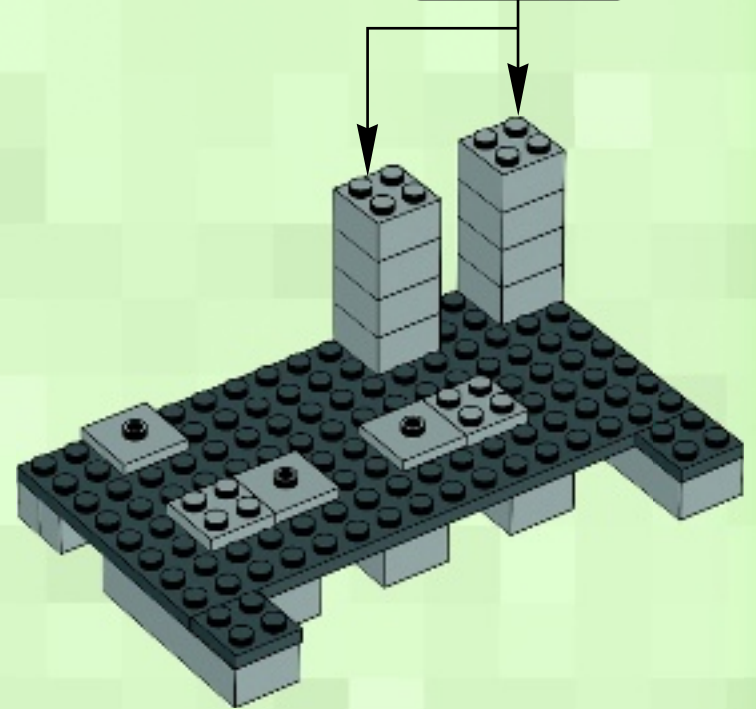
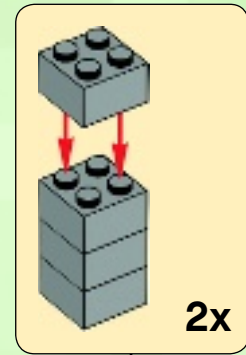

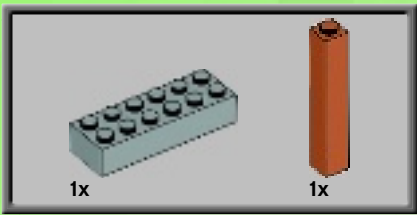

6

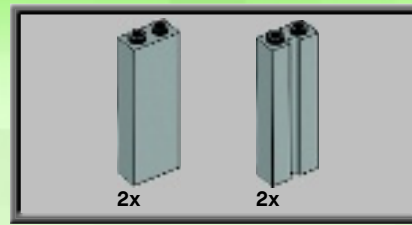
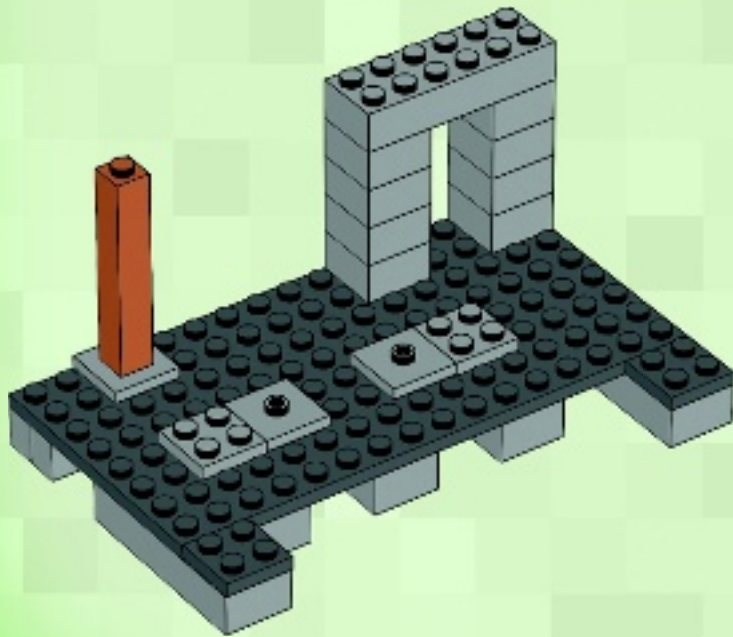

7

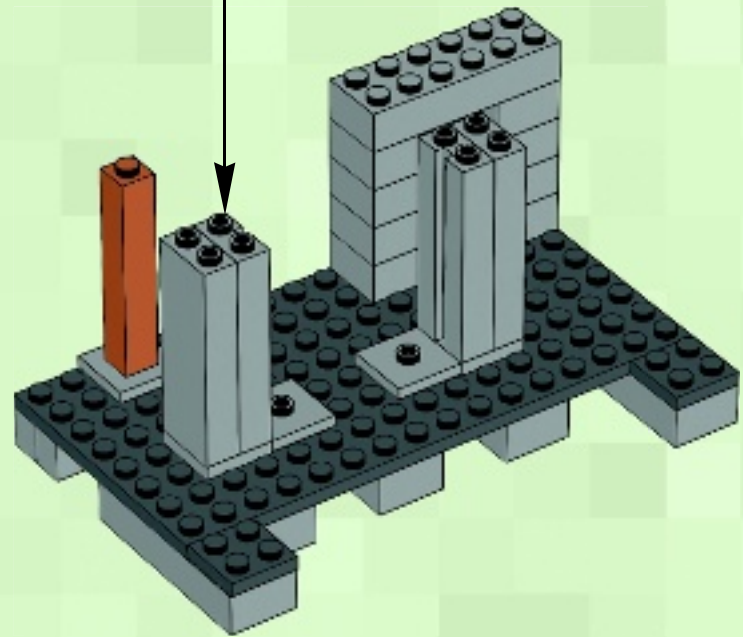
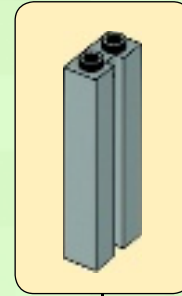

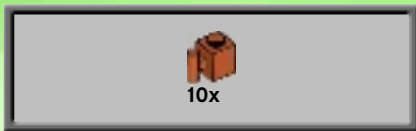

8

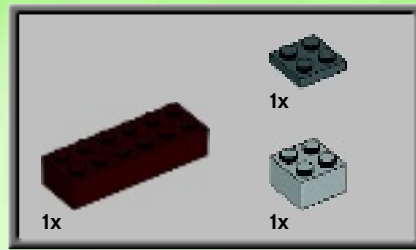
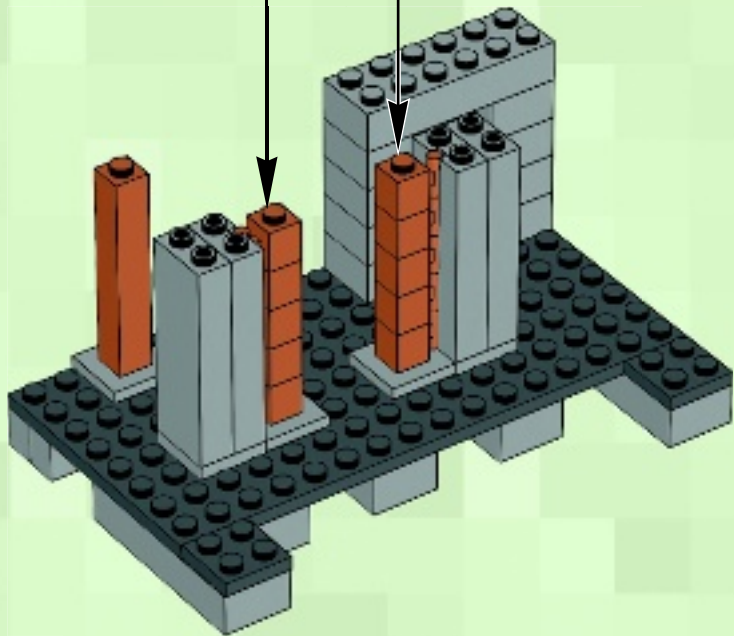
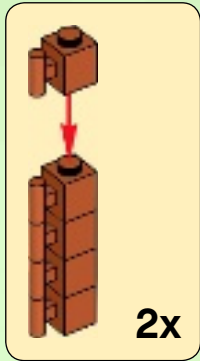

9

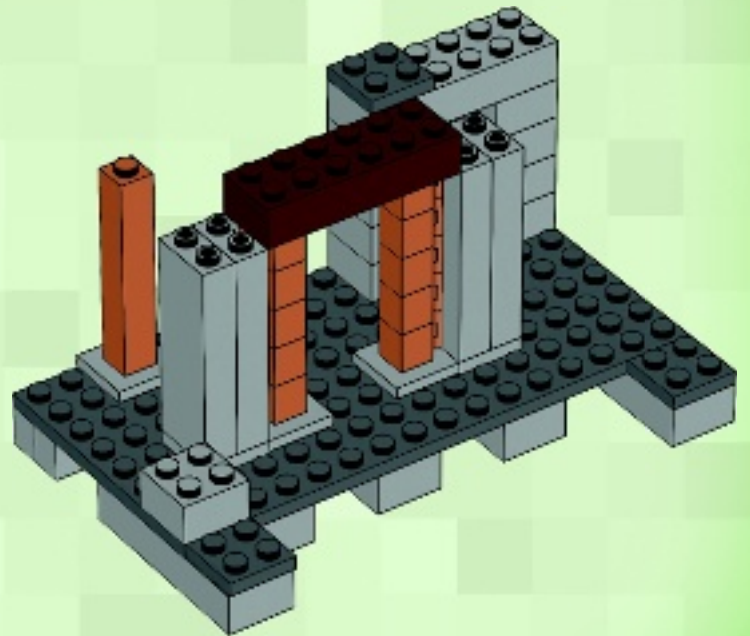

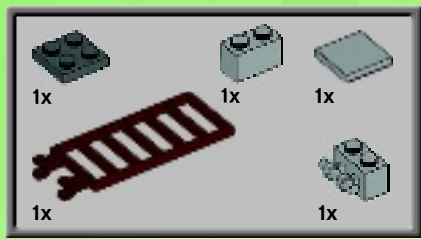

10

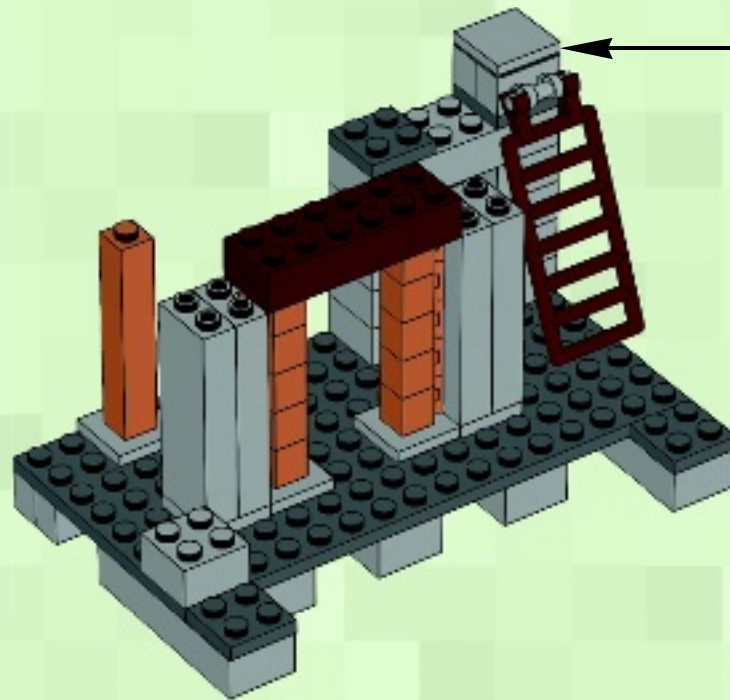
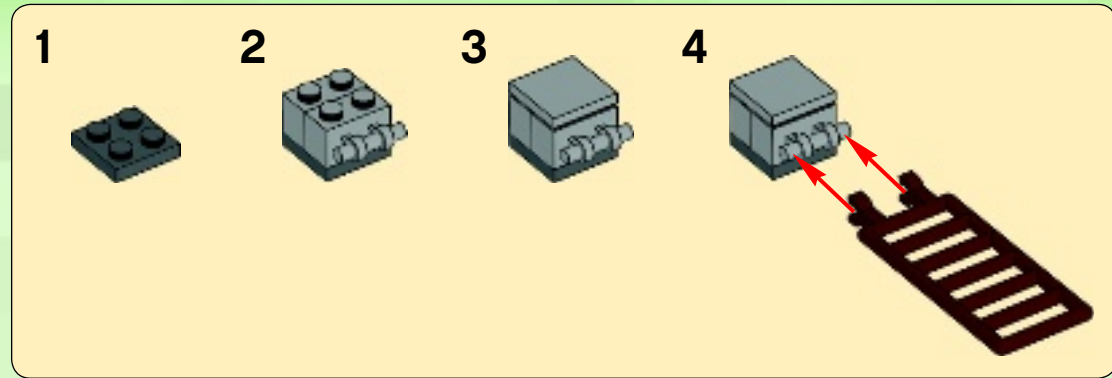

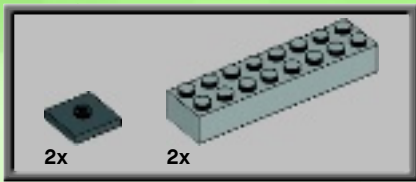

11

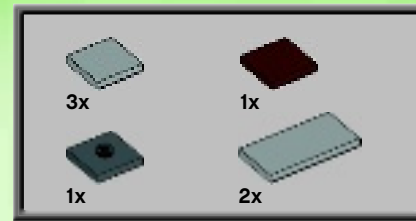
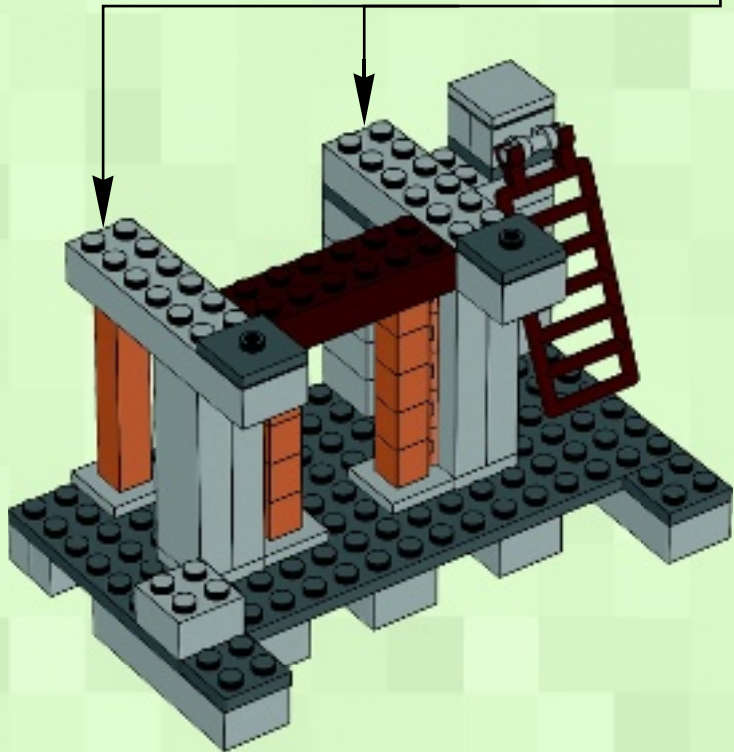
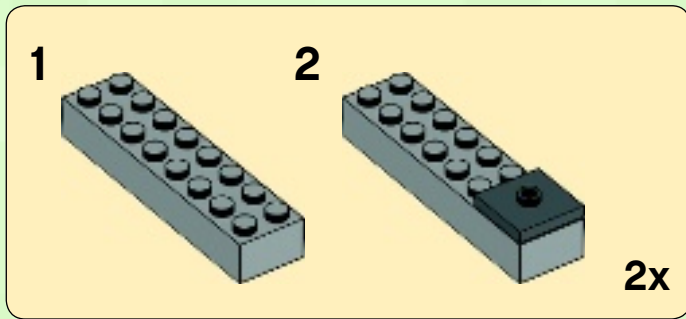

12

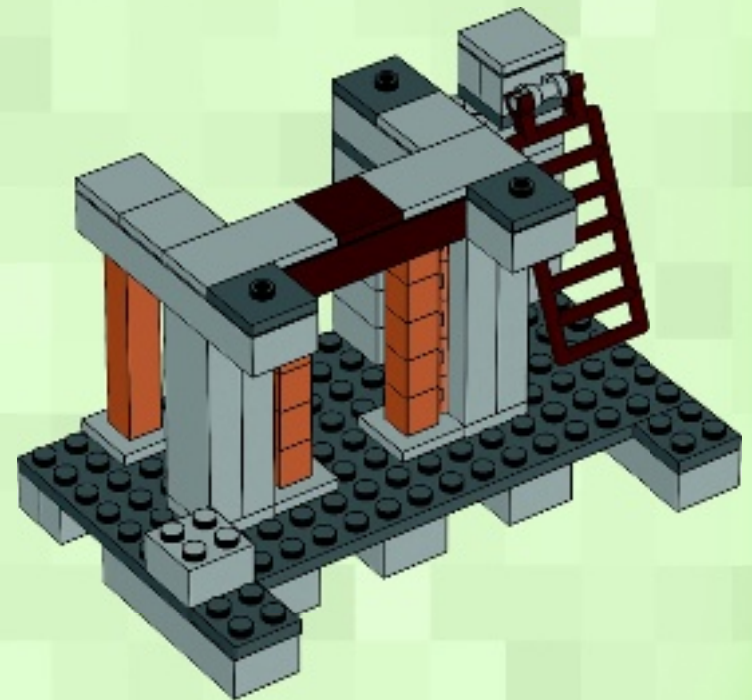

13

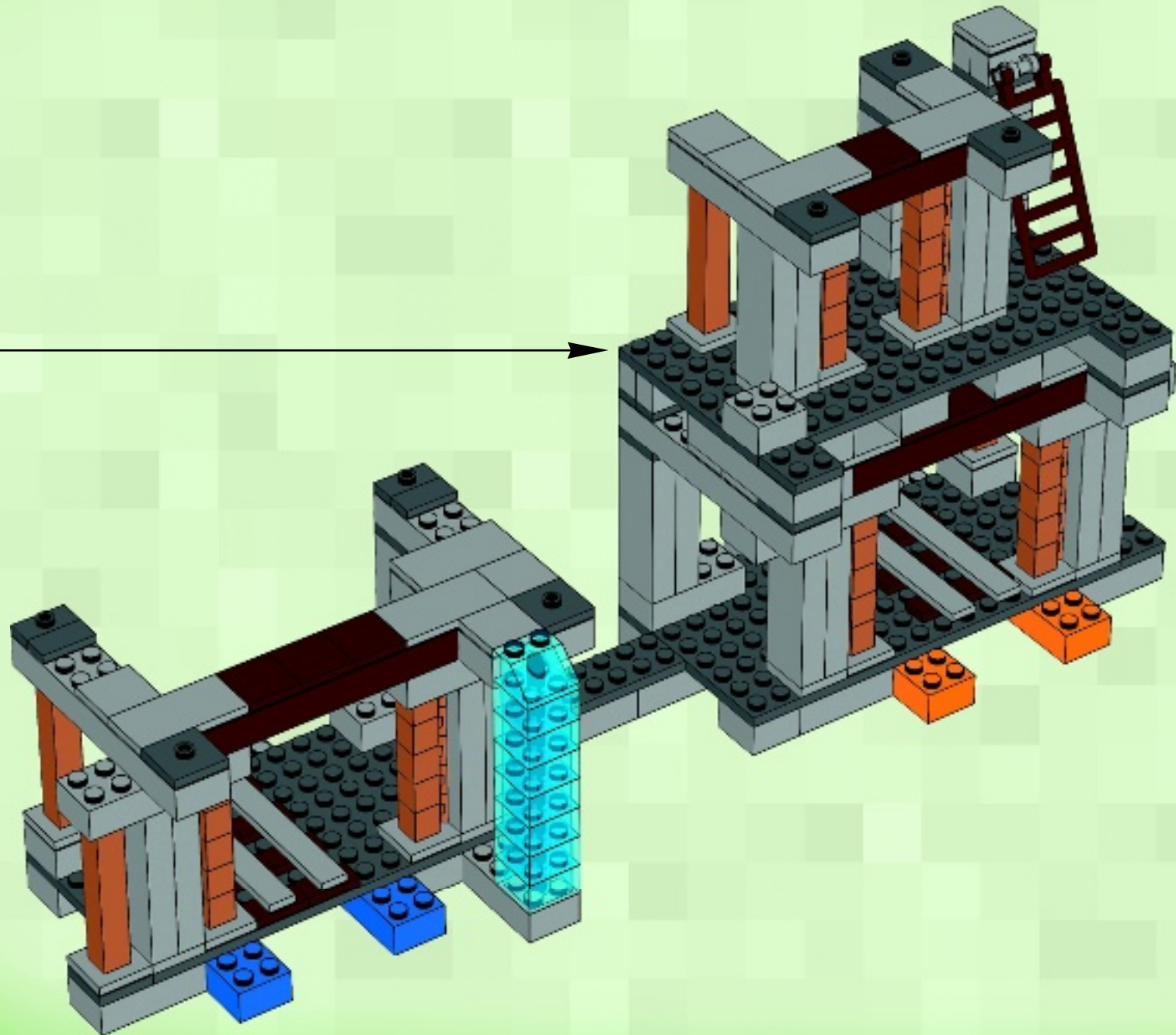



1



2



3

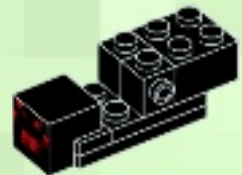

4

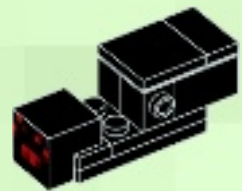



2x

5



2x

2x

2x

6

1



2



2x



2x

2x

2x

7

1



2



2x

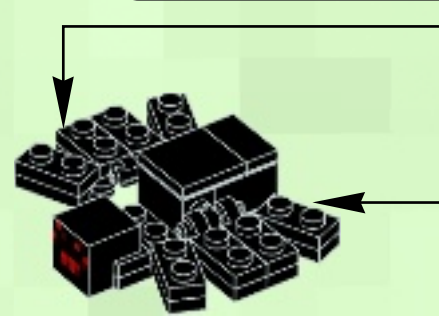

8



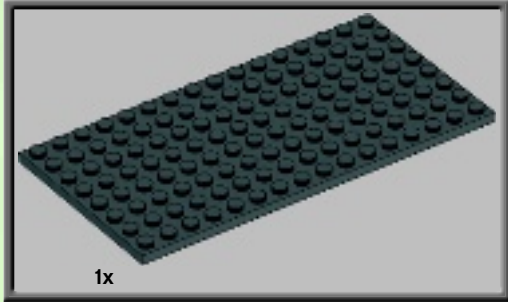
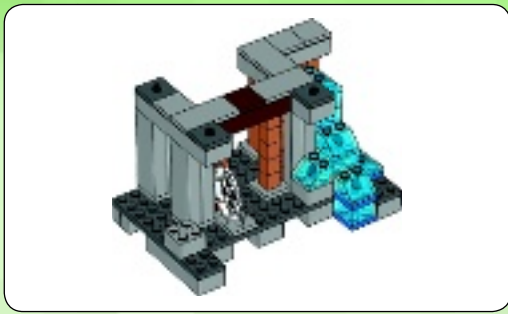

1

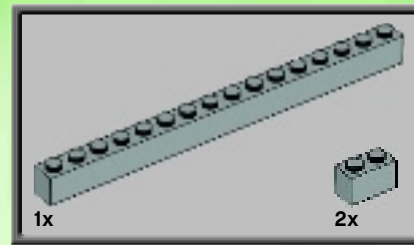
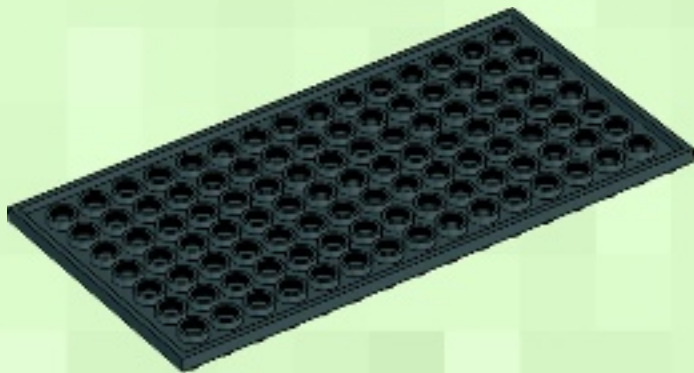

2

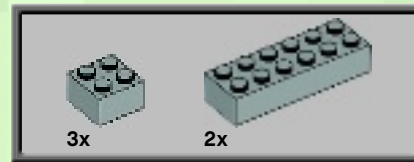
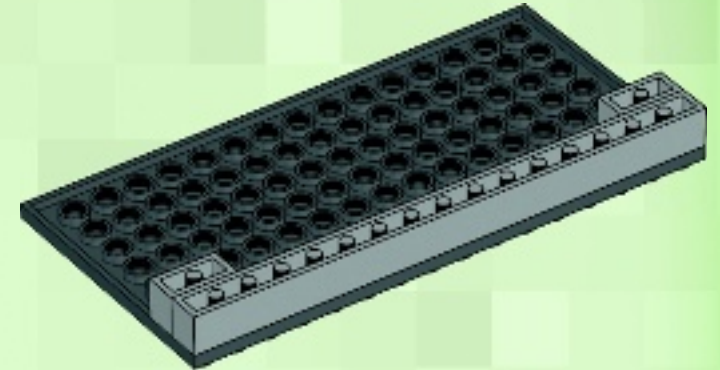

3

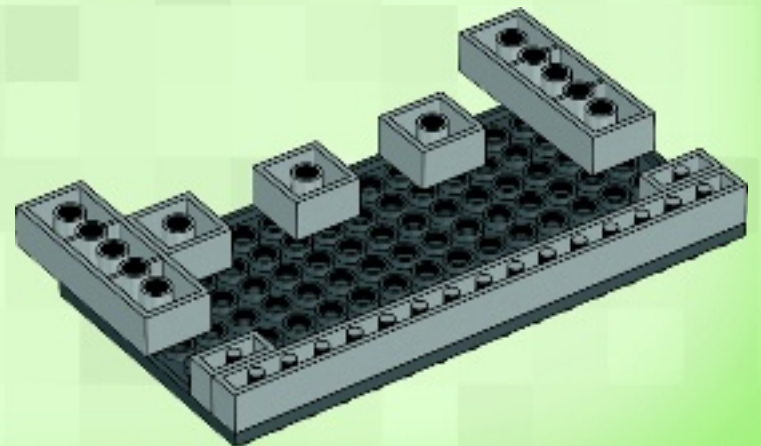



4

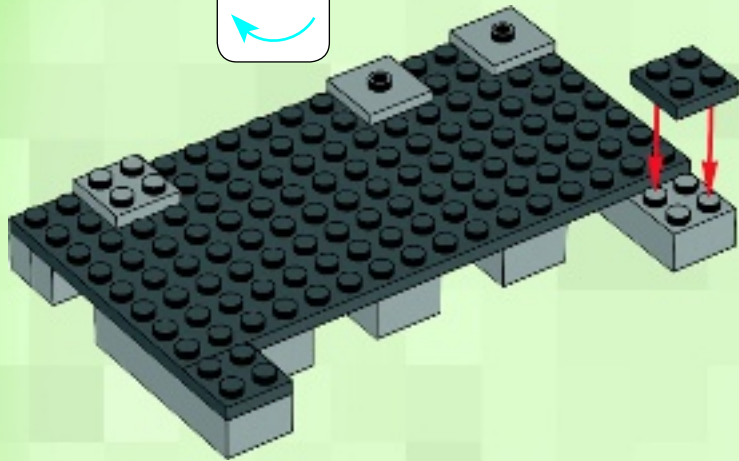
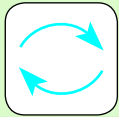

5

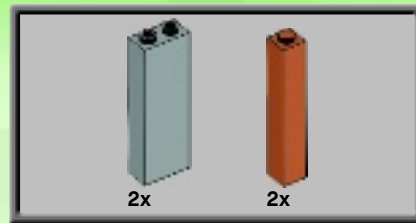
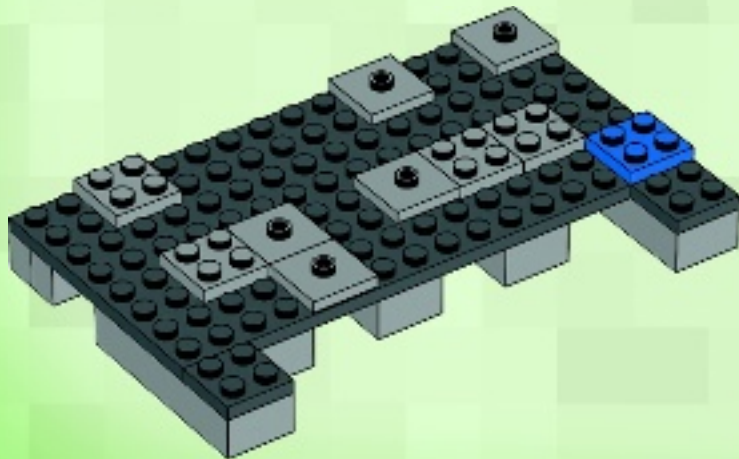

6

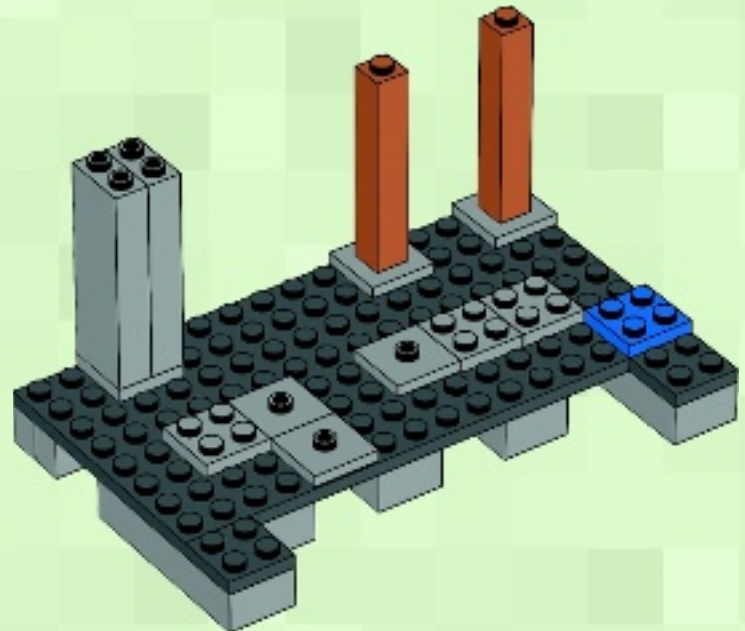

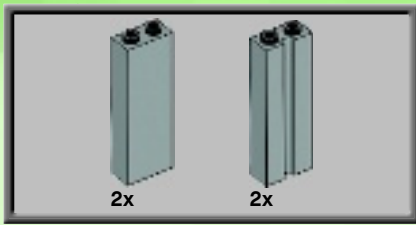

7

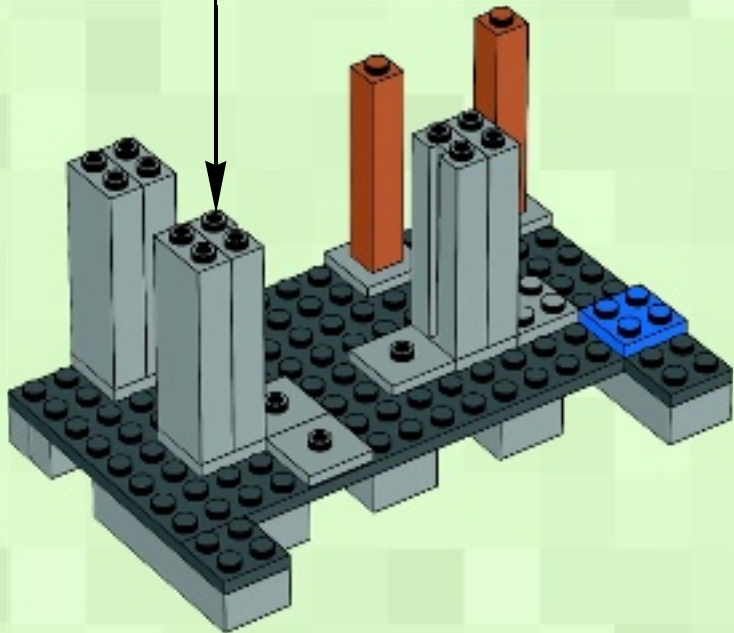
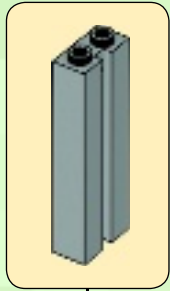

8

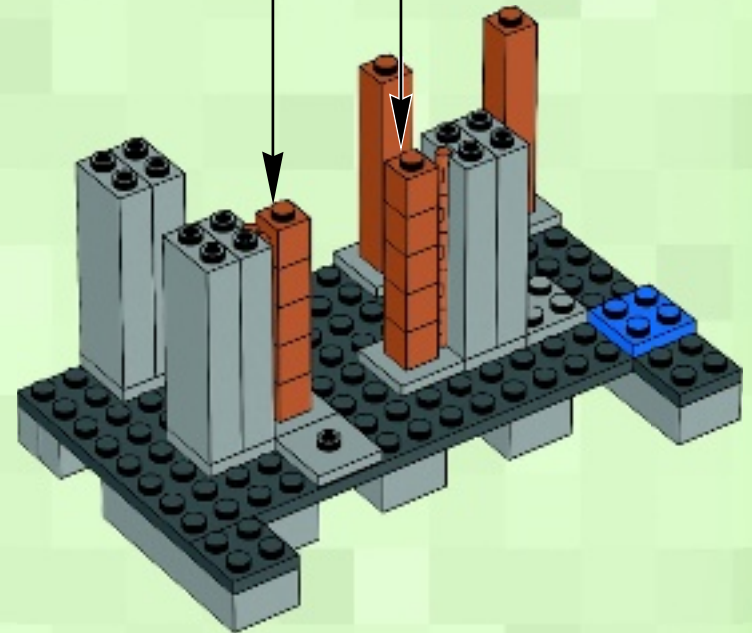
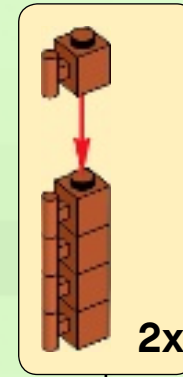



9

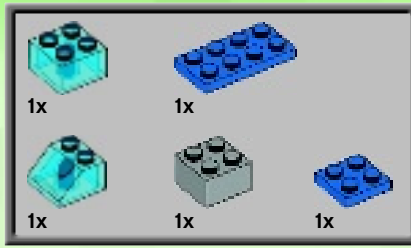
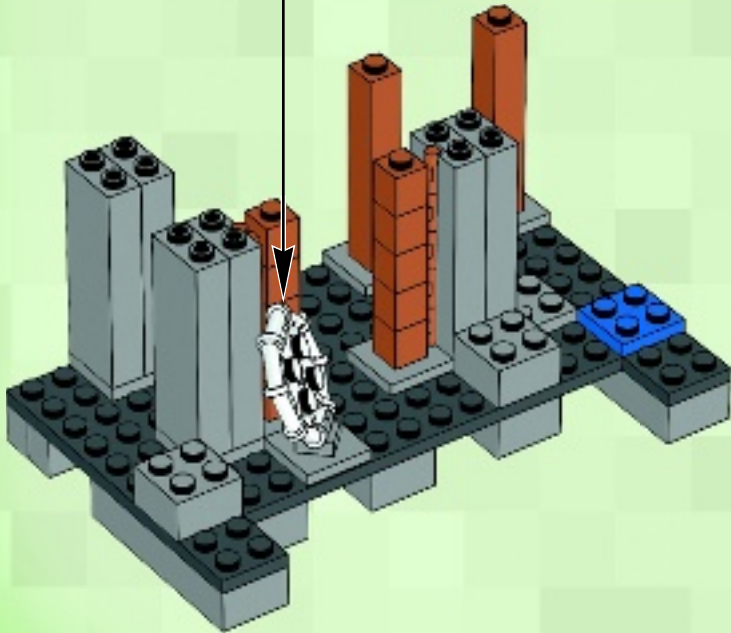
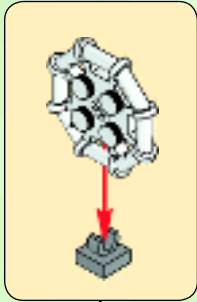

10

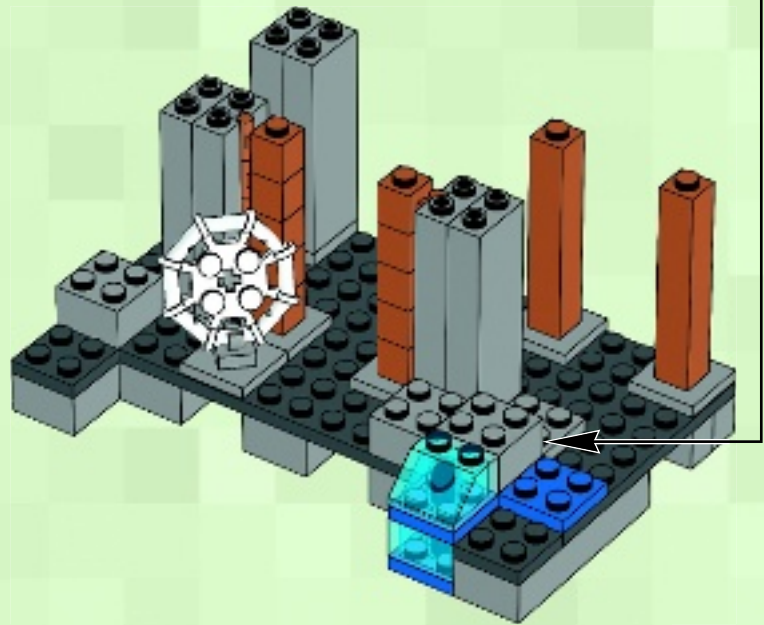
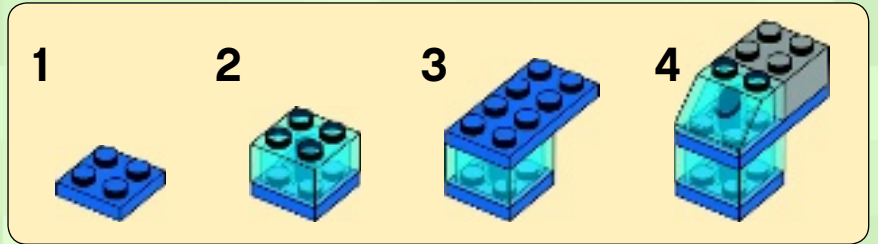

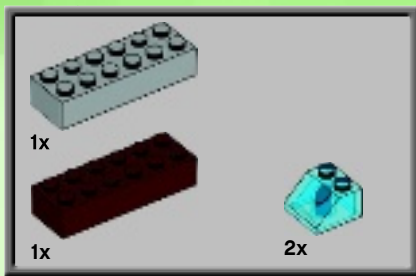

11

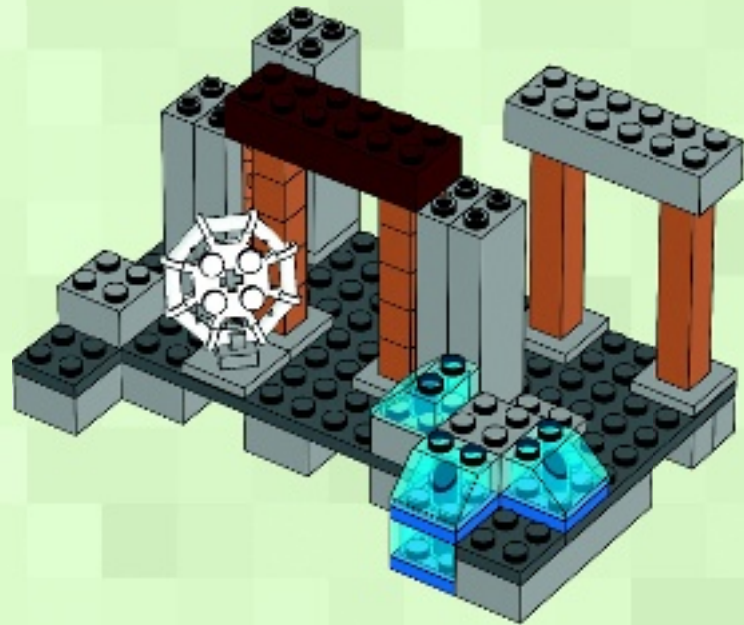

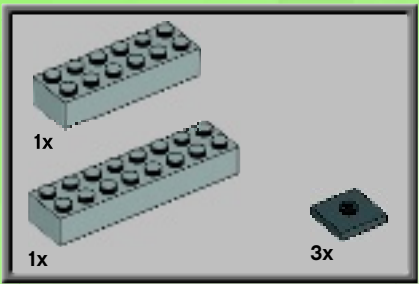

12

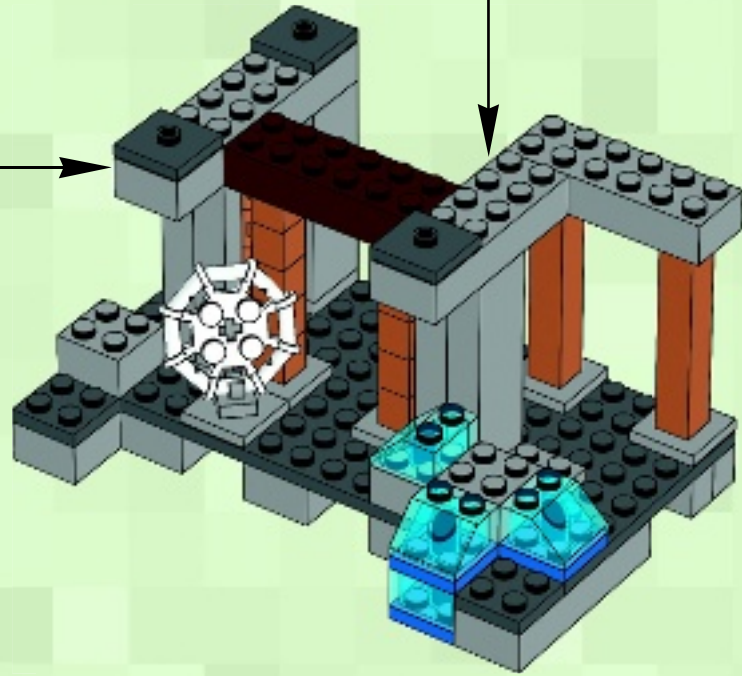
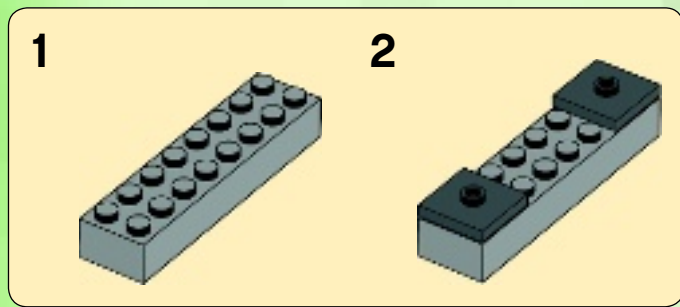
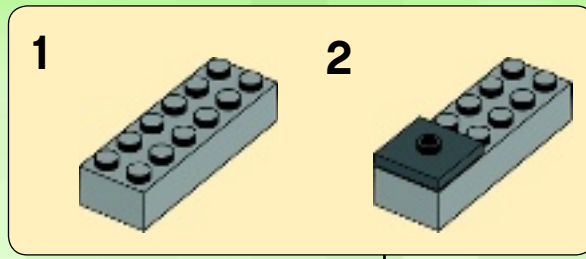

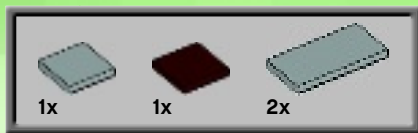

13

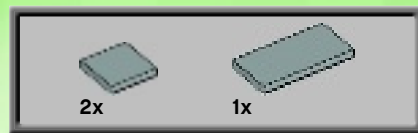
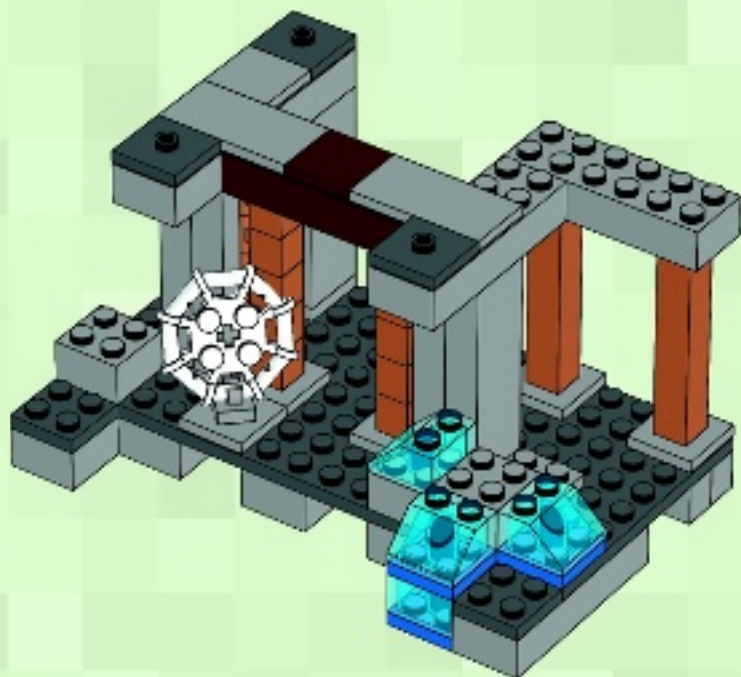

14

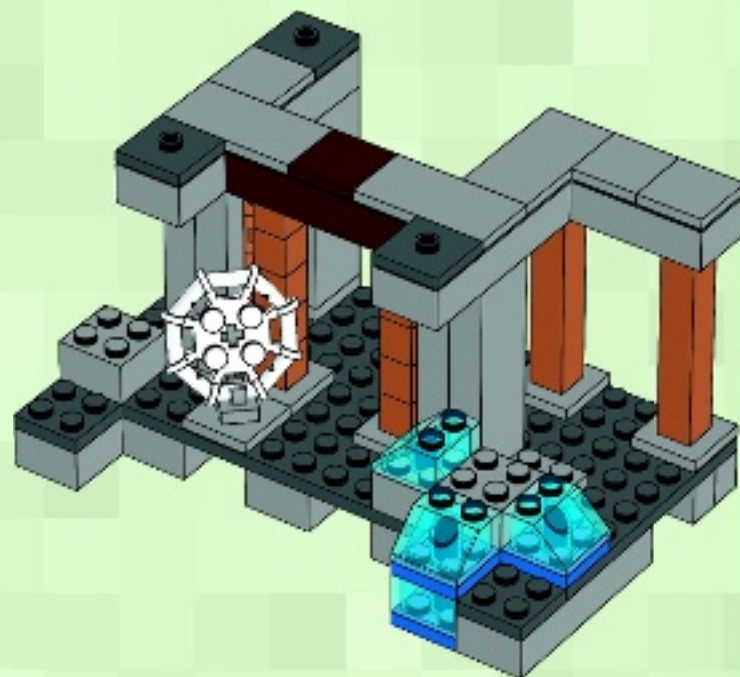



15

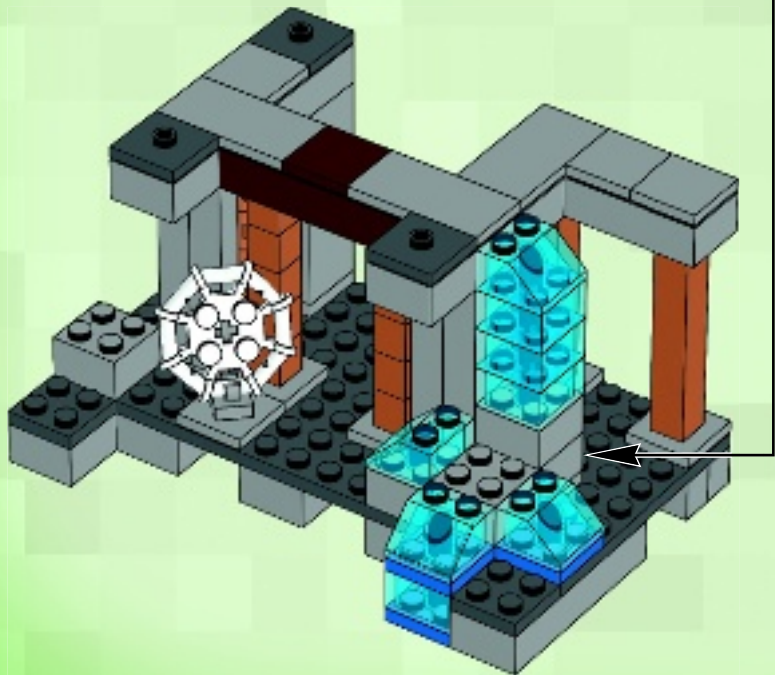
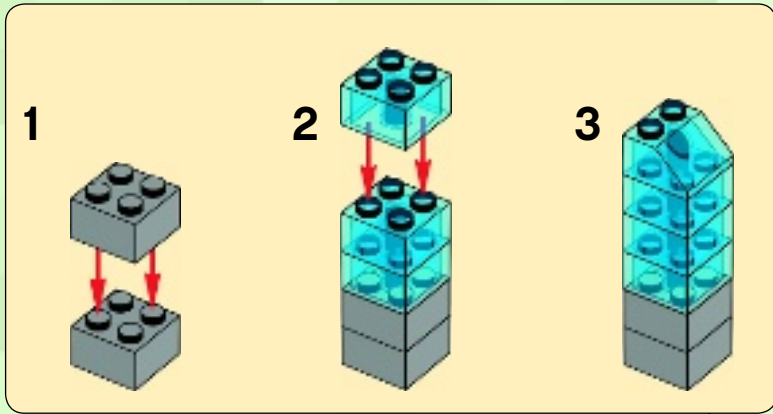

16

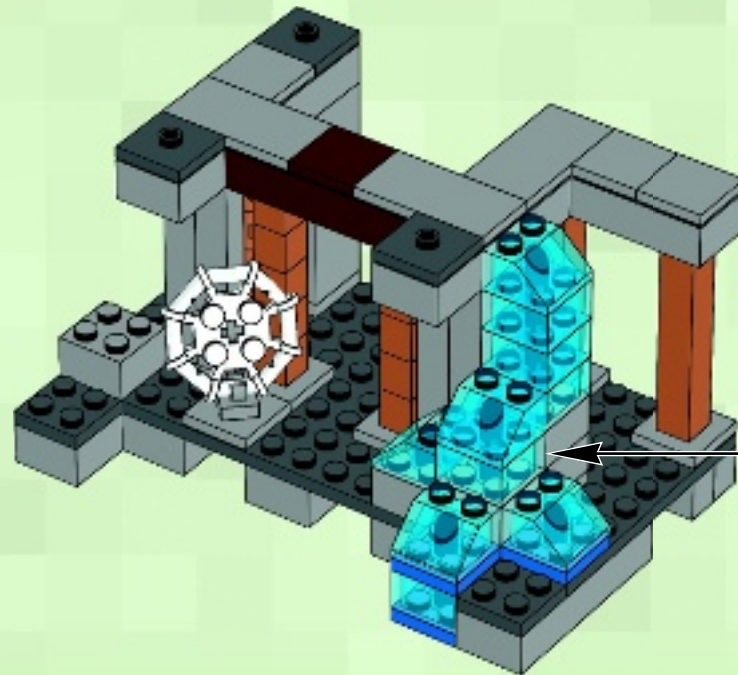
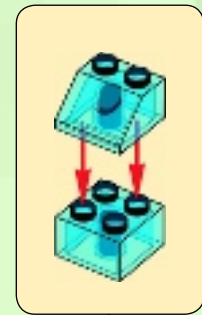

17

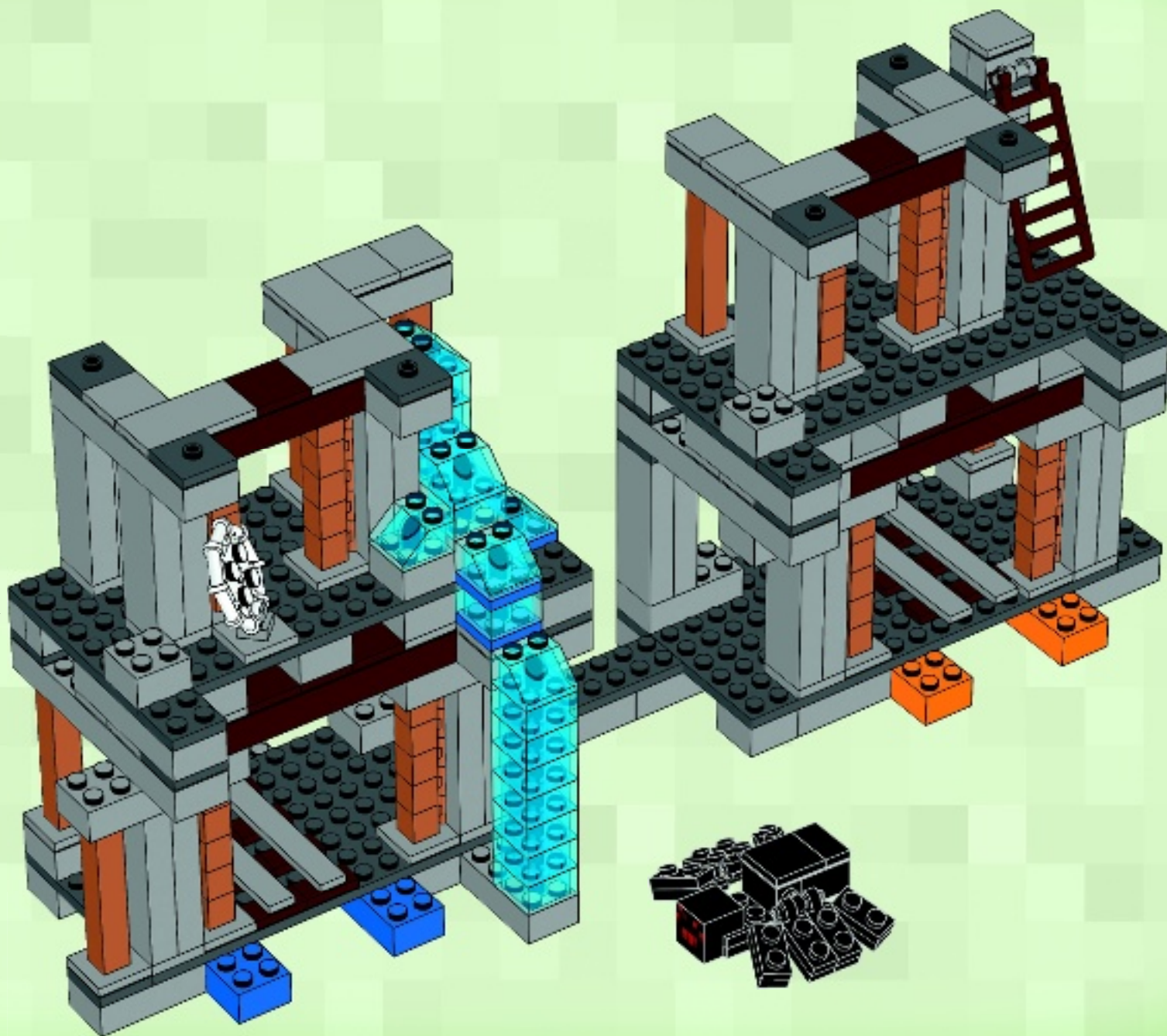

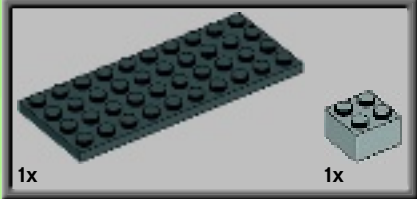

1

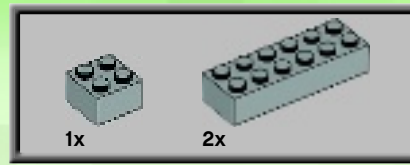
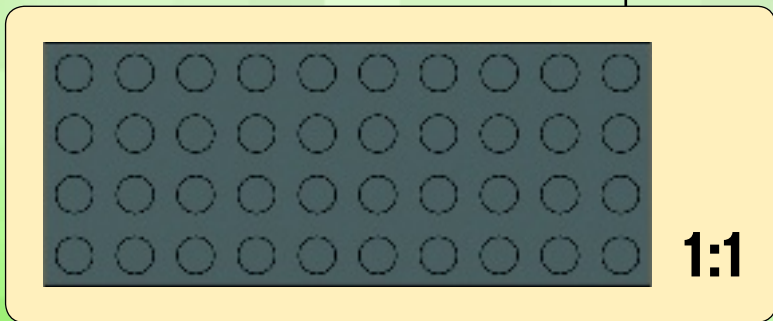
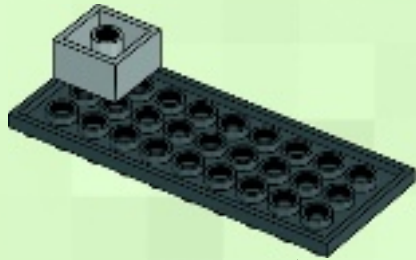

2

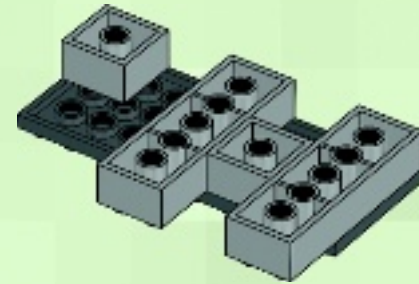

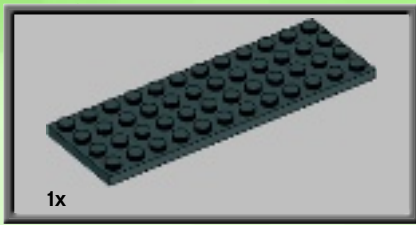

3

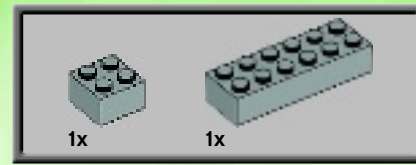
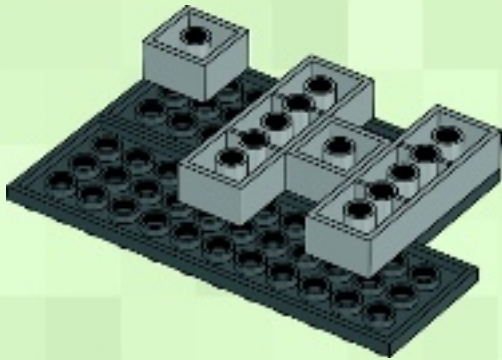

4

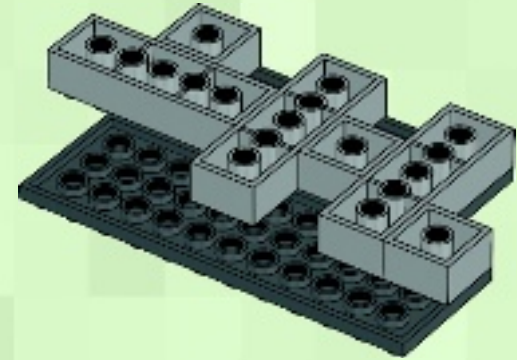

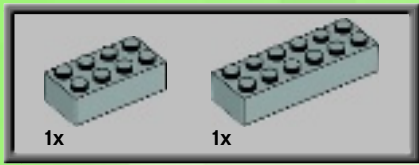

5

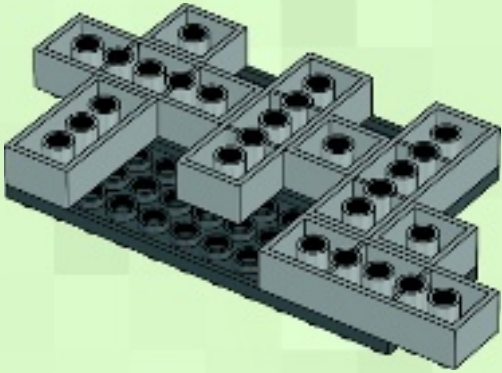

6

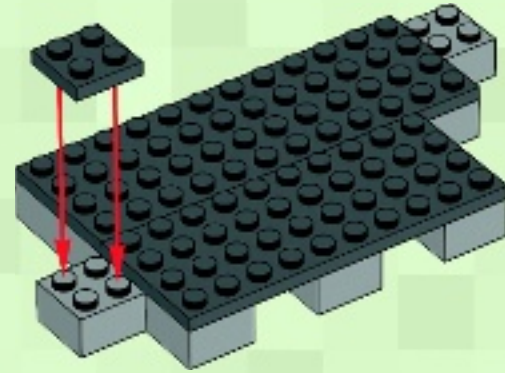
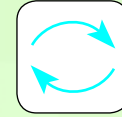



7

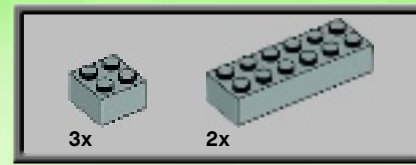
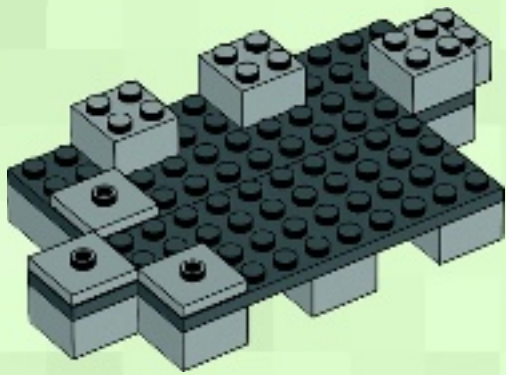

8

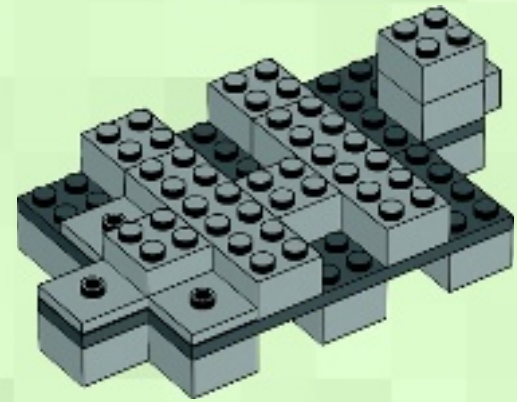



9

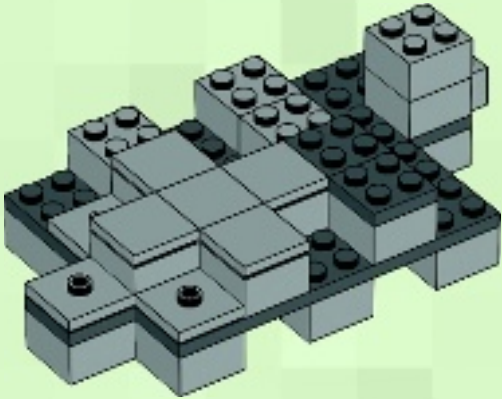

10

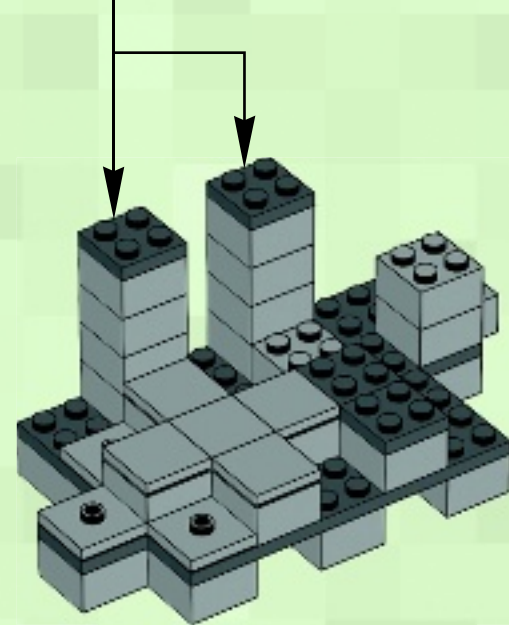
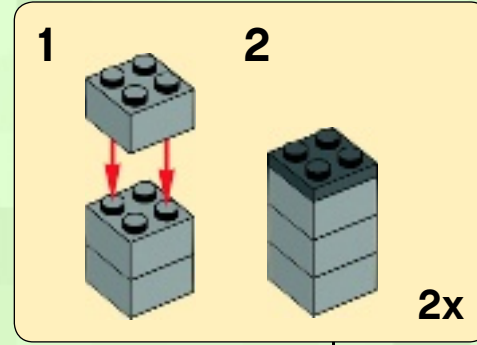



1

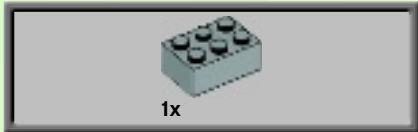

2

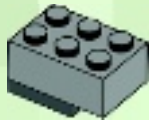

3

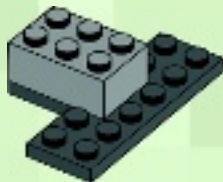

4



5

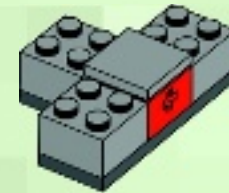

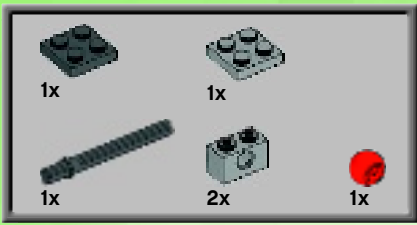

6

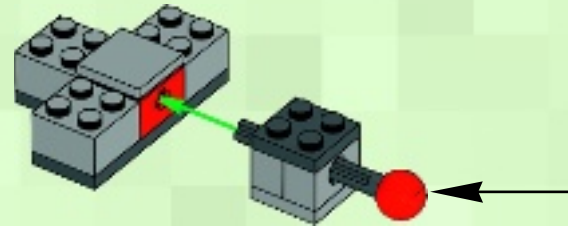
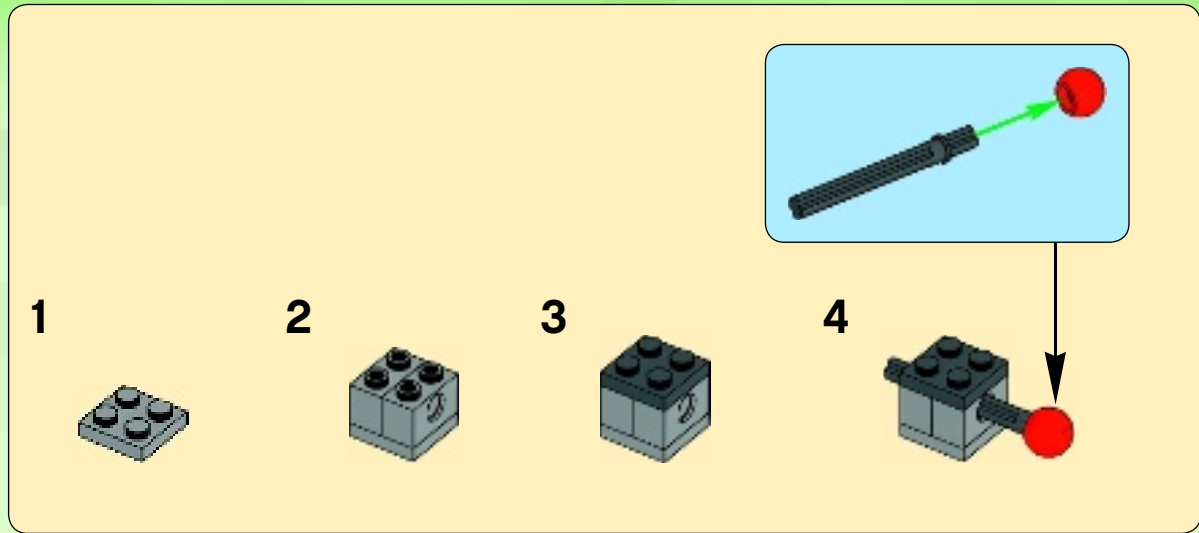

11

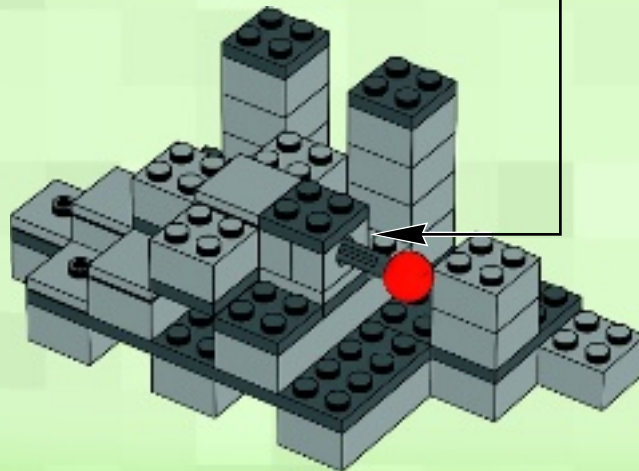



12

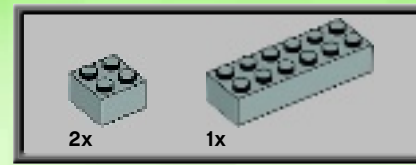
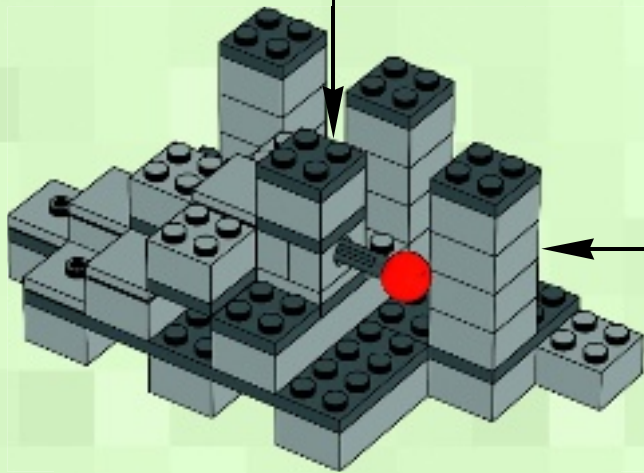
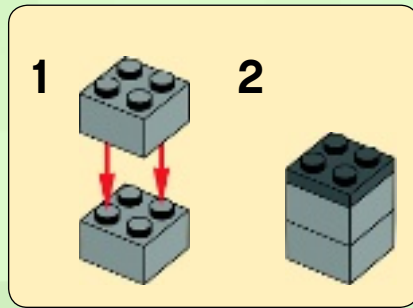
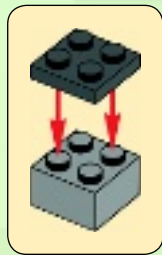

13

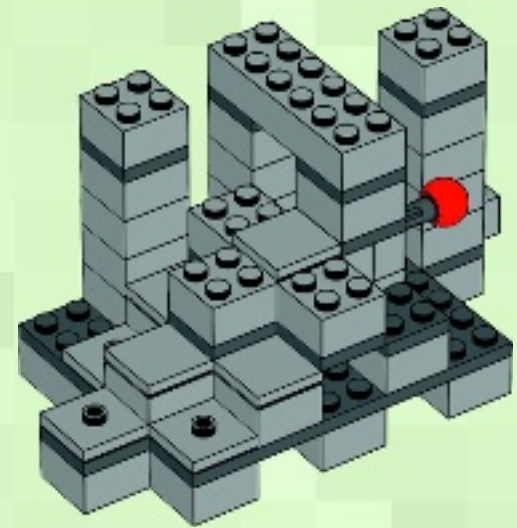



14

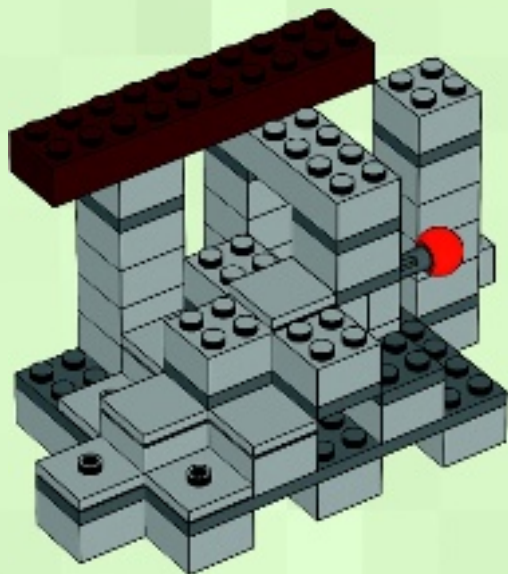

15

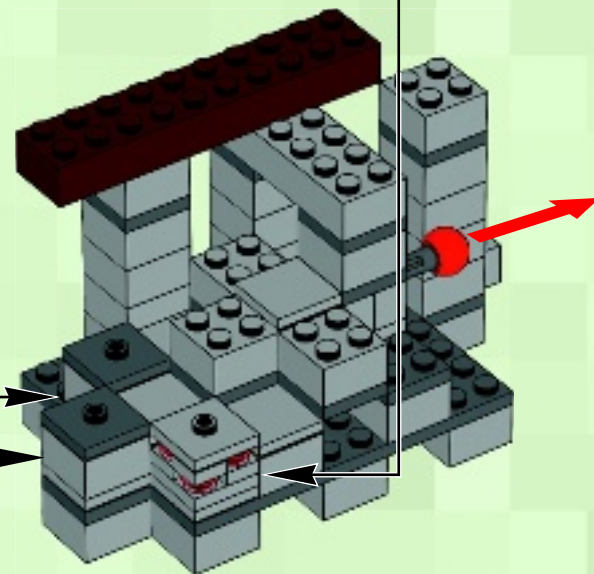
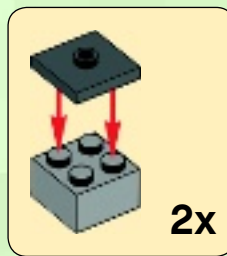



16

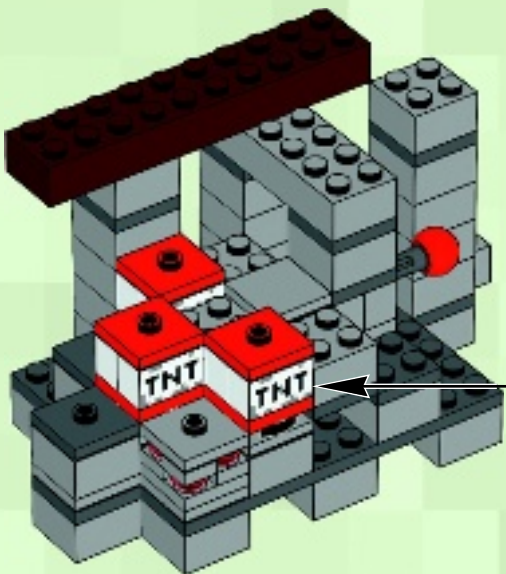

17

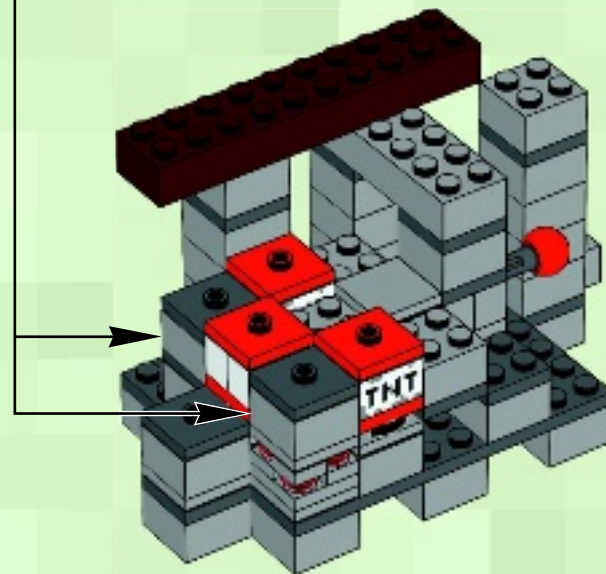
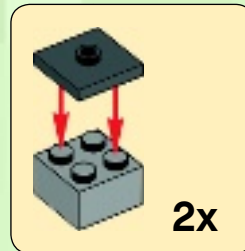



18

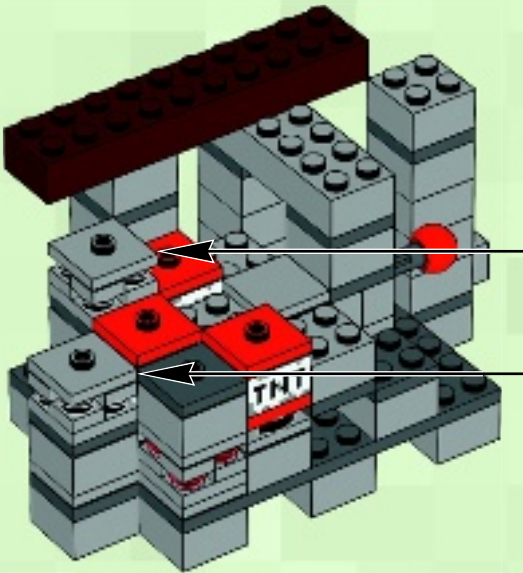
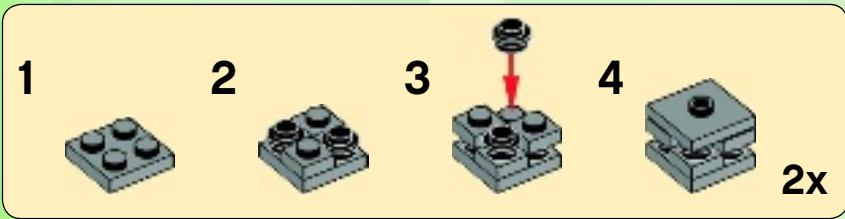

19

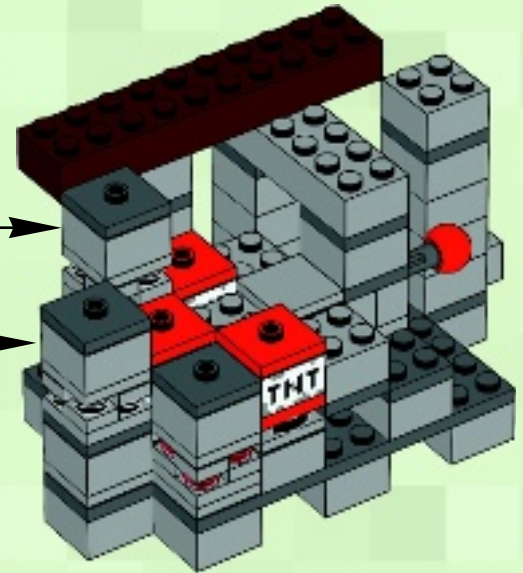
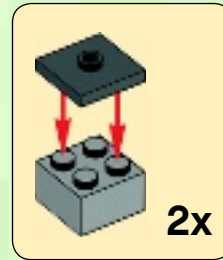

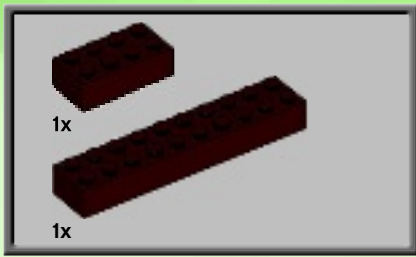

20

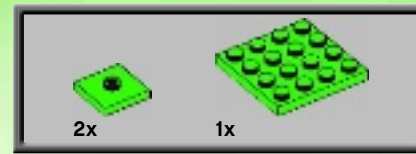
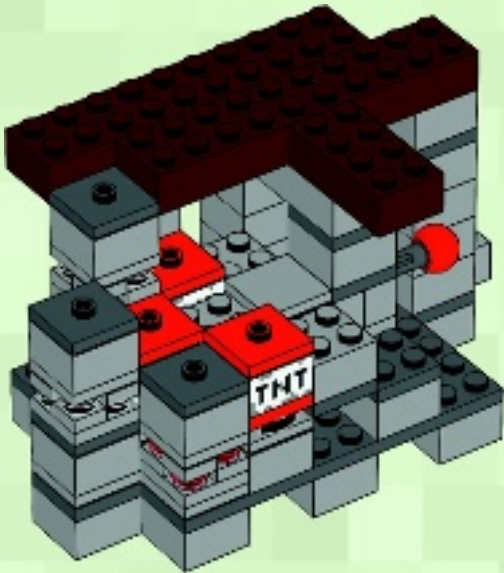

21

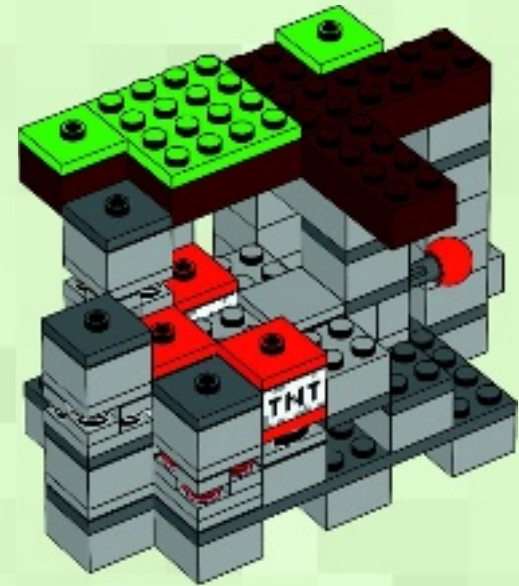

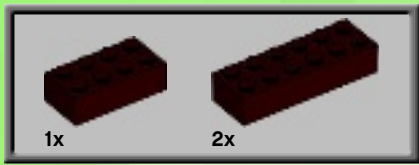

22

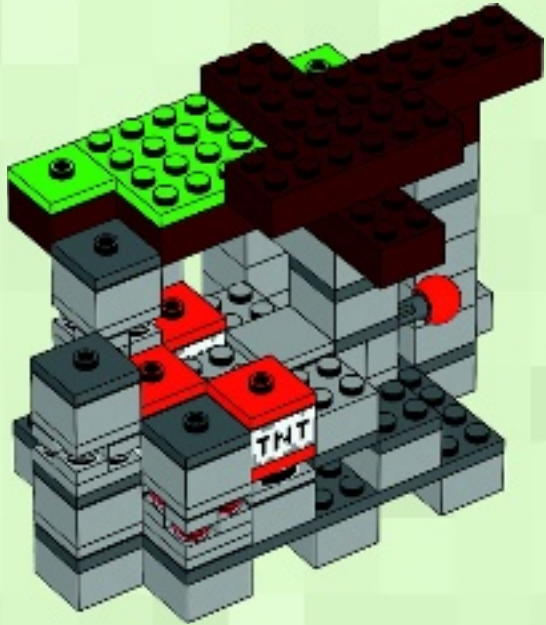

23

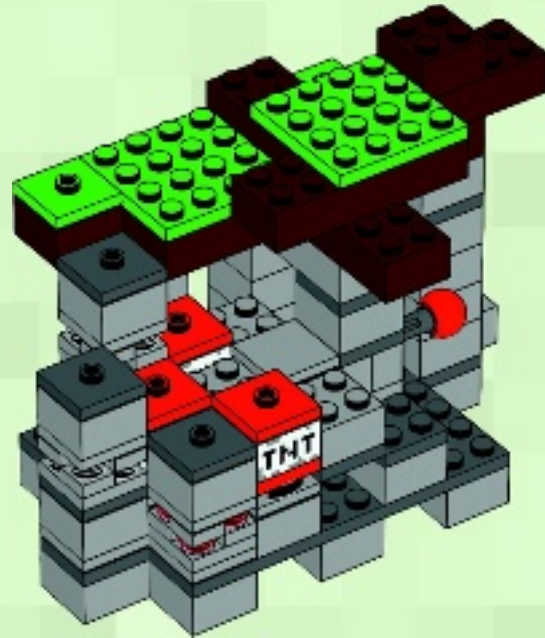



24

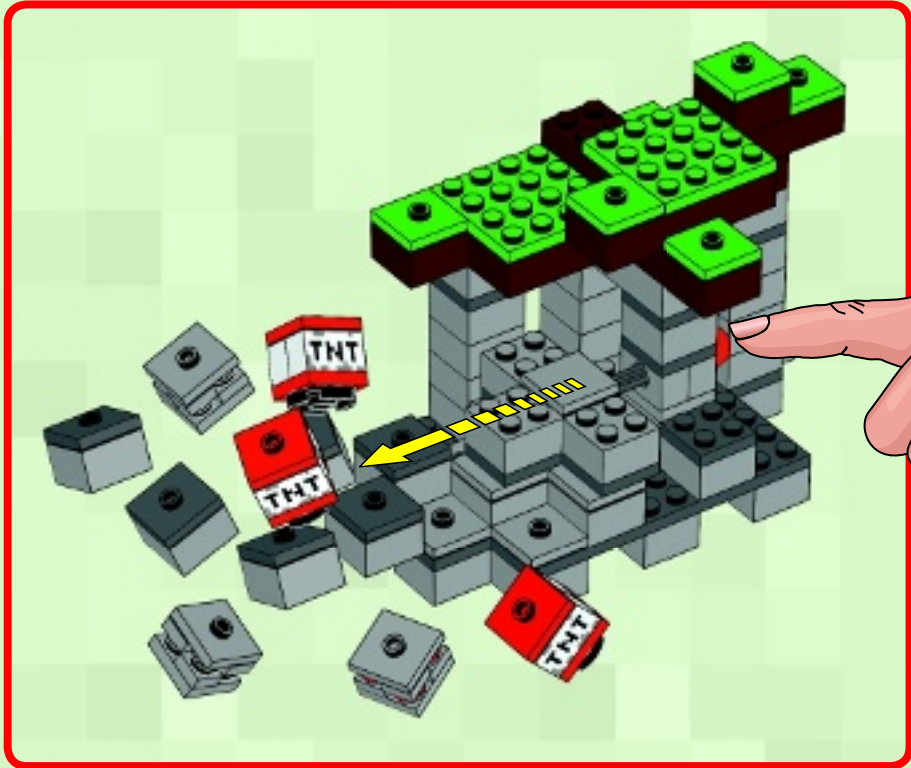
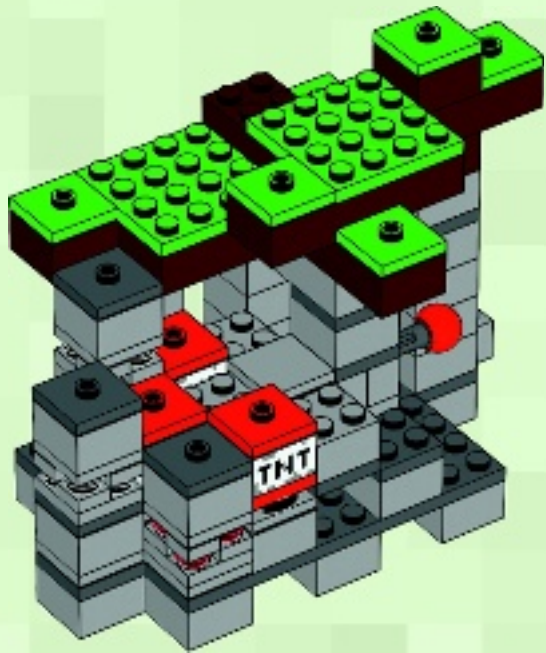



1



2



3

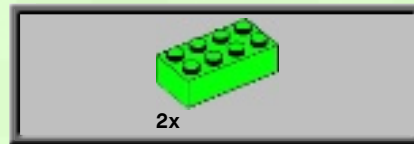

4

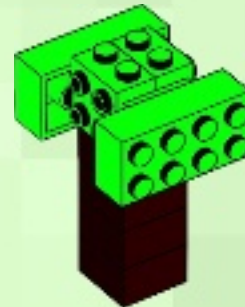



5

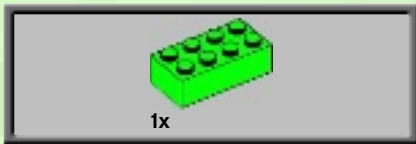
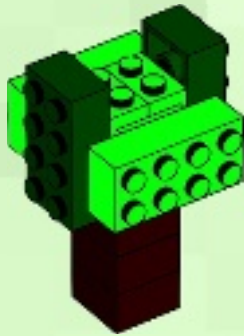

6

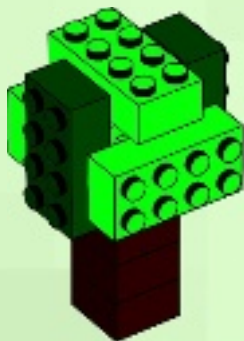

25

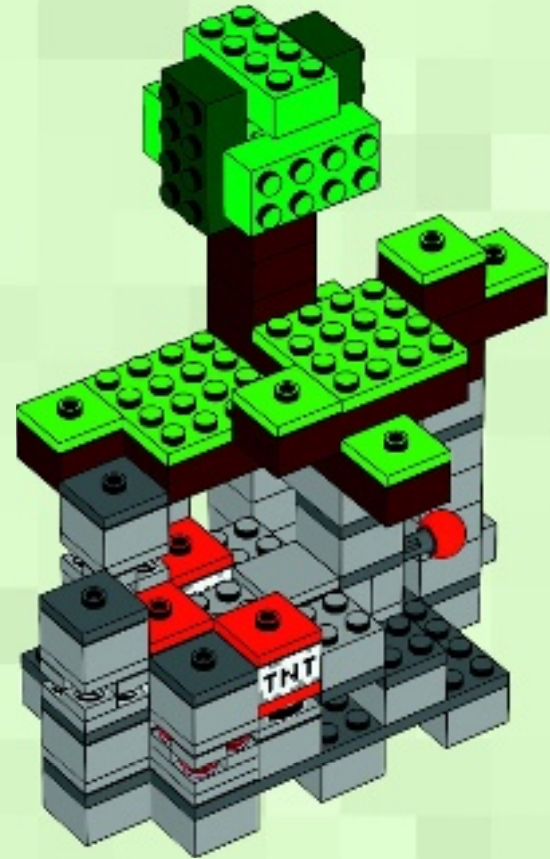

26

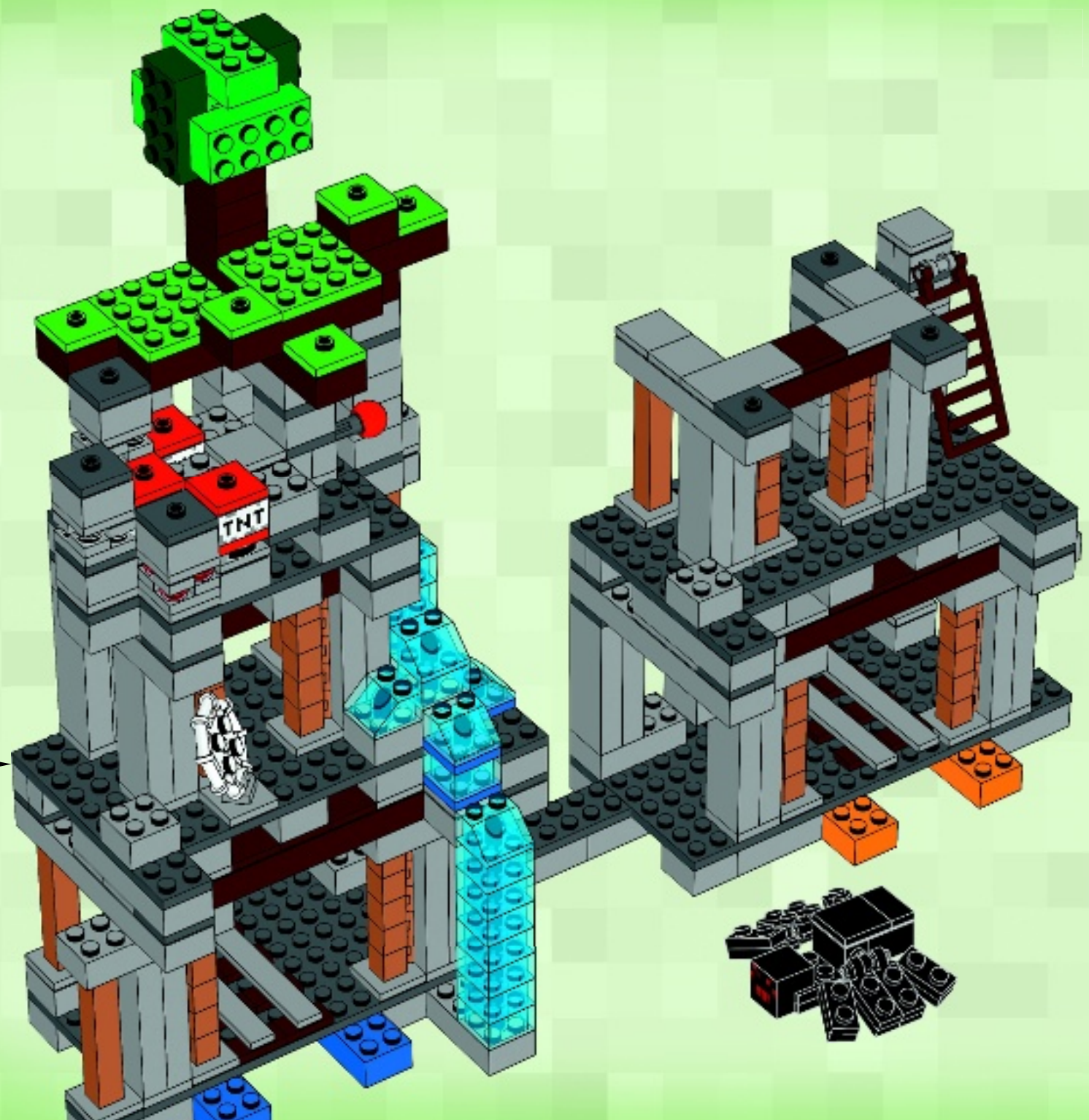

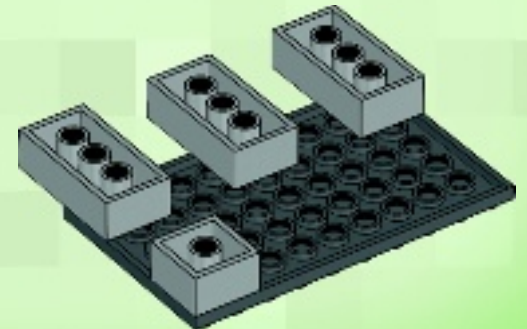
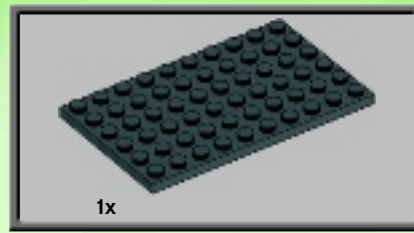
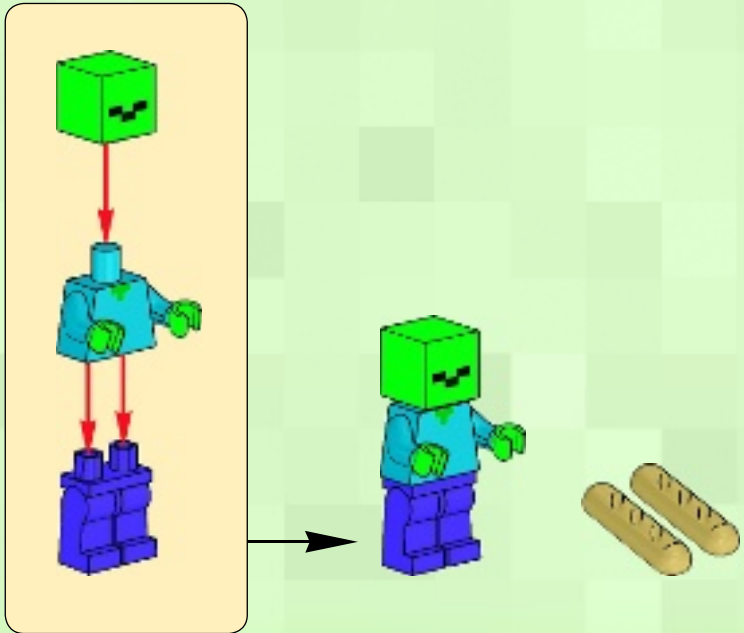
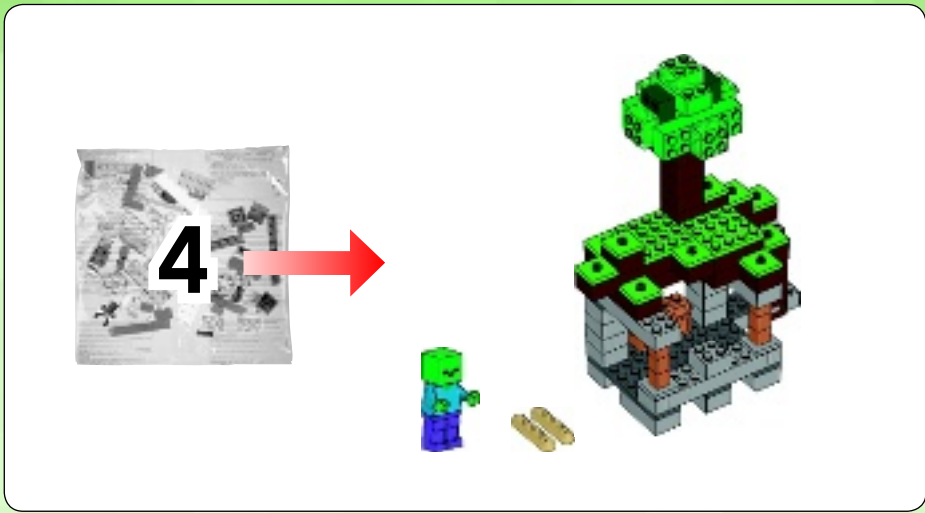



3

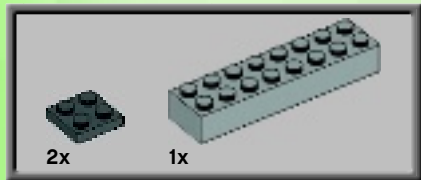
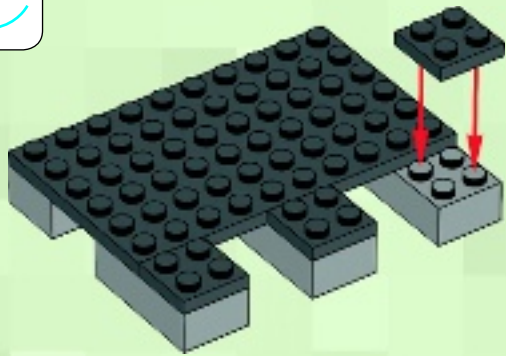

4

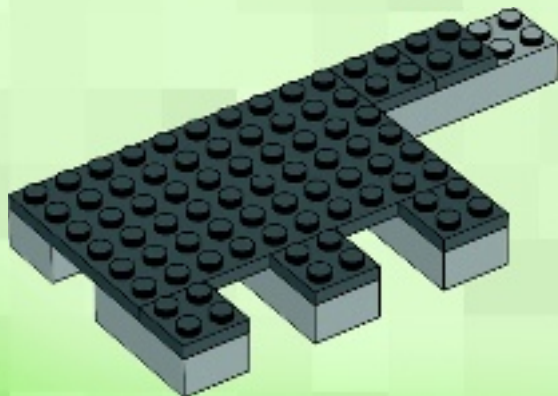
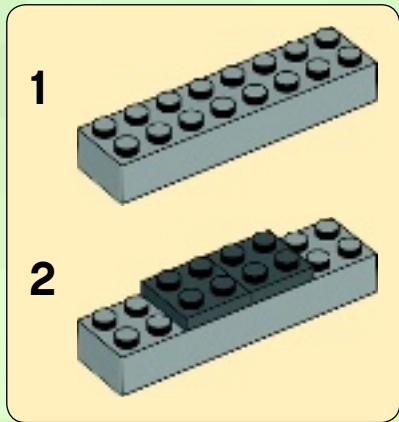

5

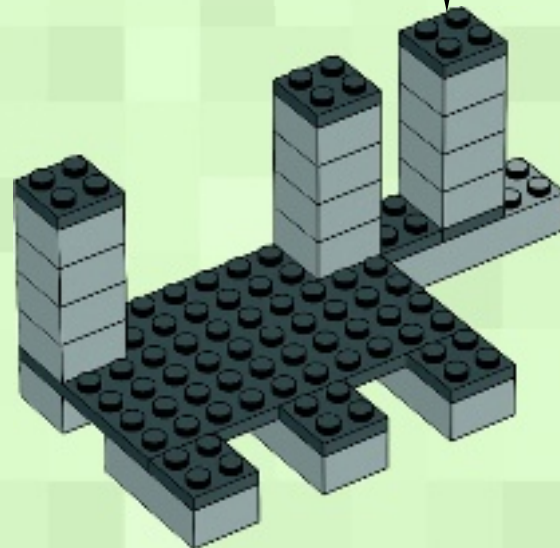
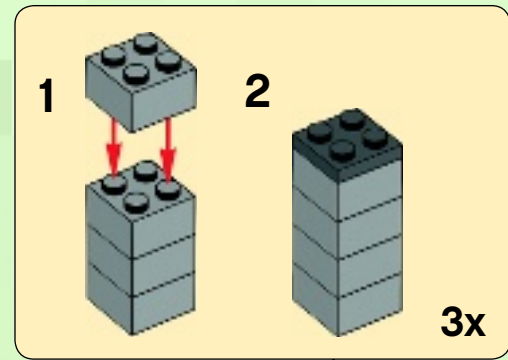

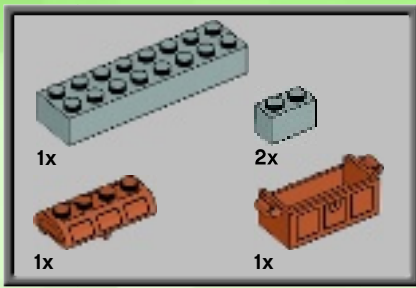

6

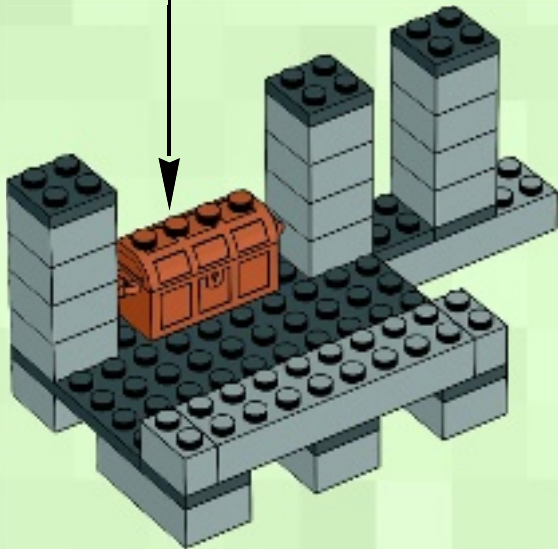
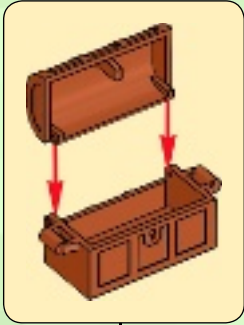

7

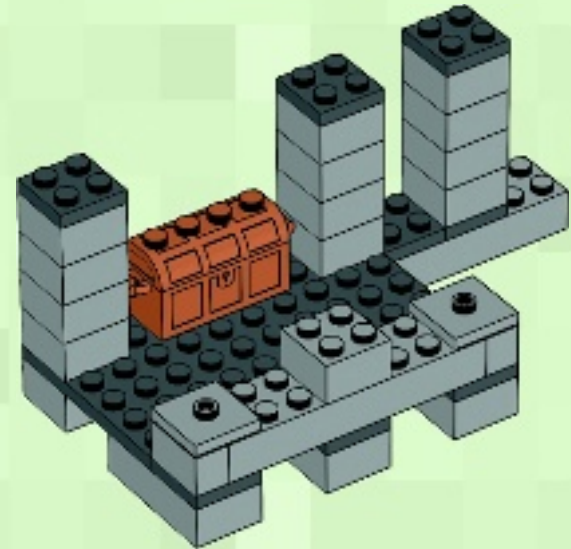



8

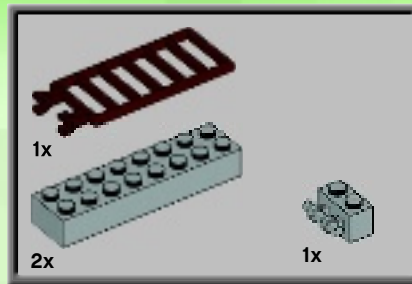
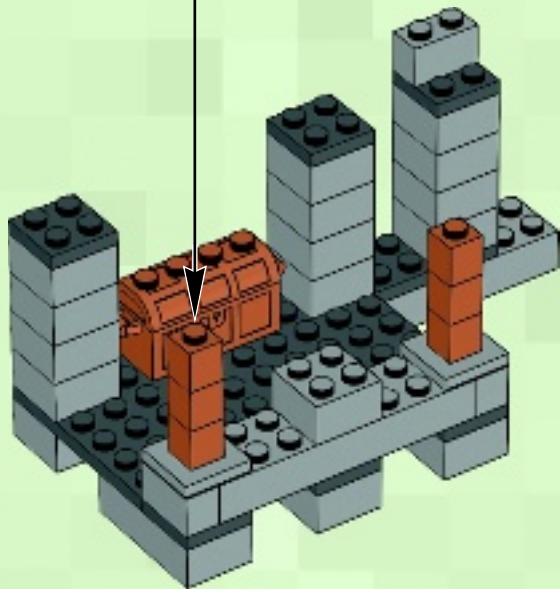
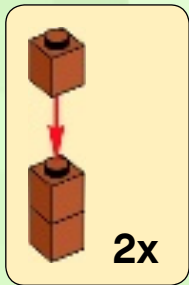

9

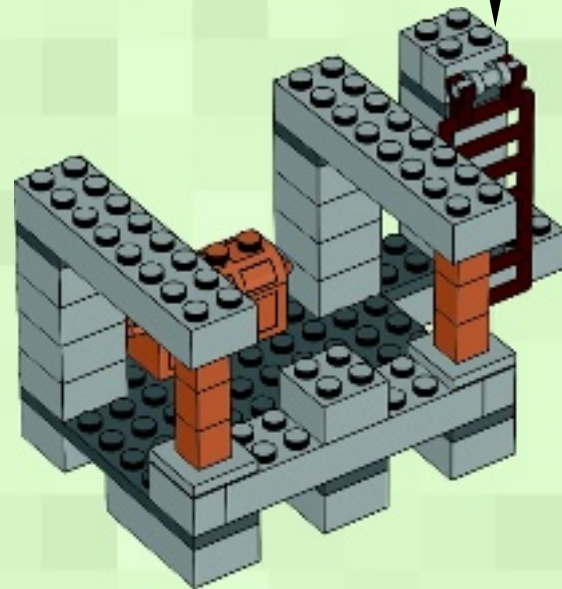
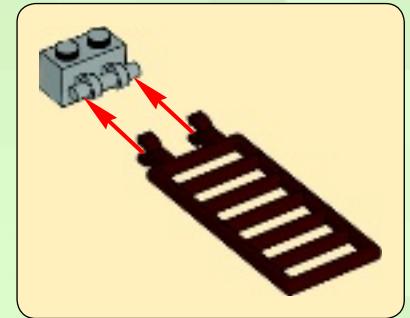

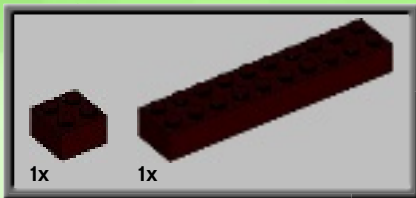

10

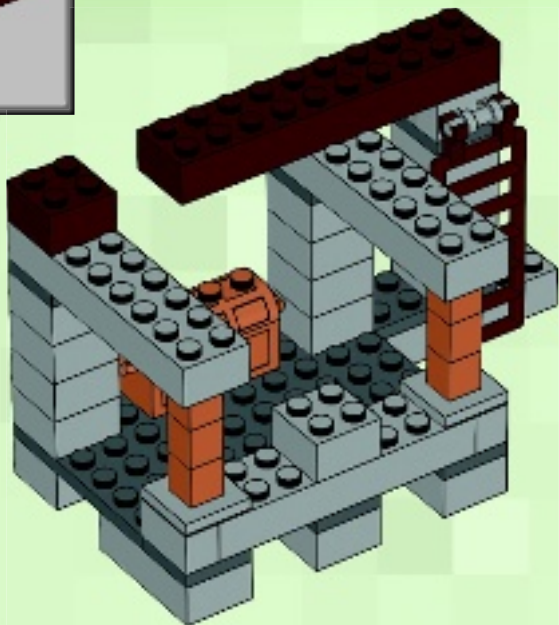

11

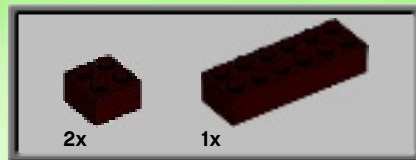
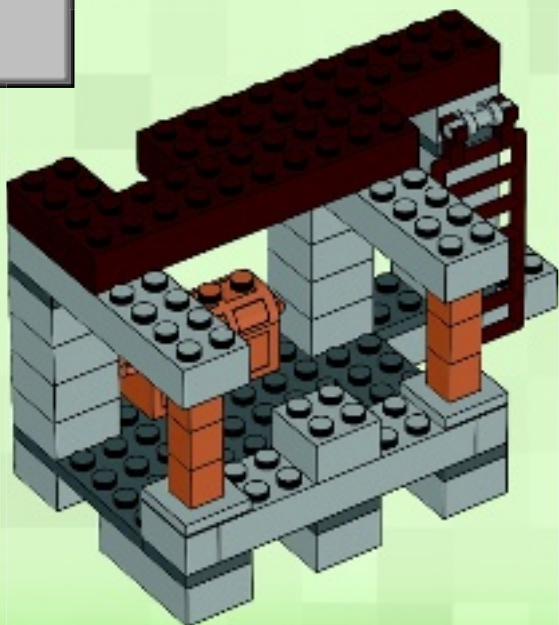

12

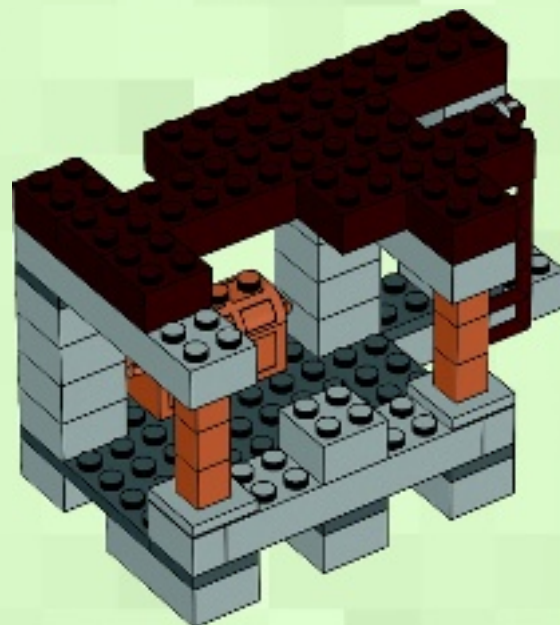

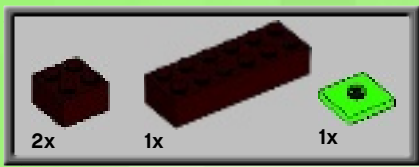

13

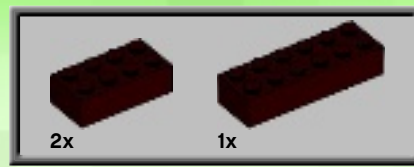
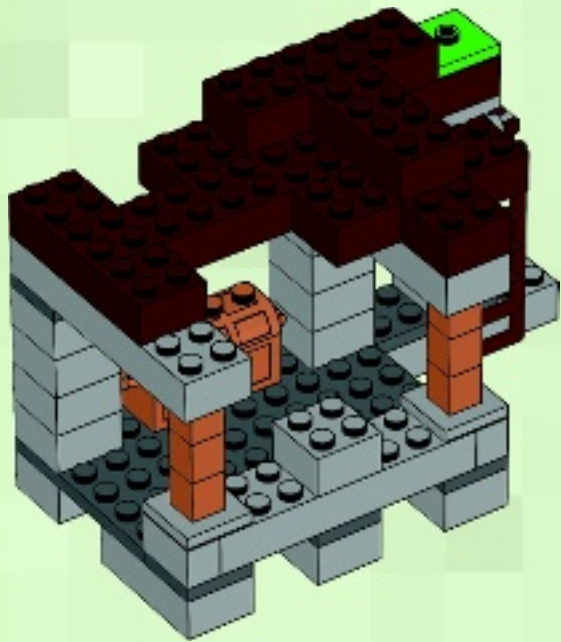

14

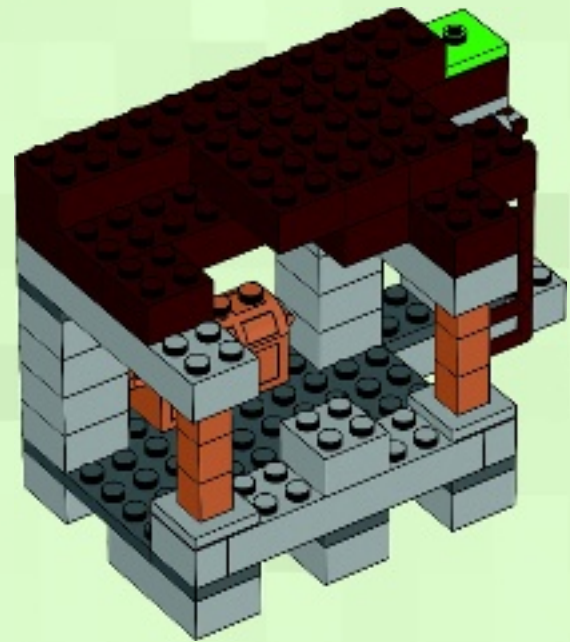



15

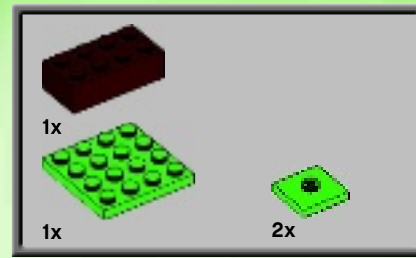
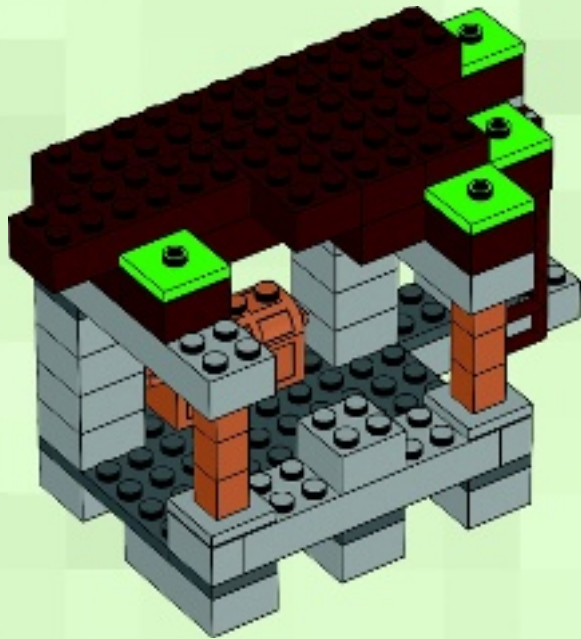

16

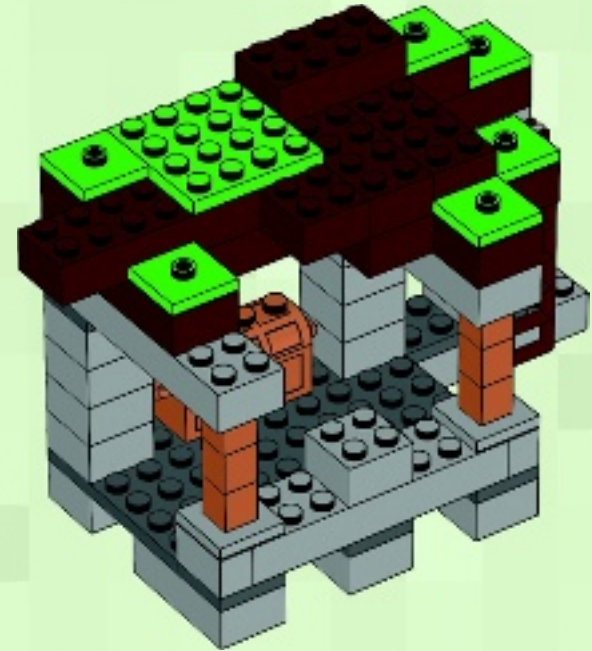



17

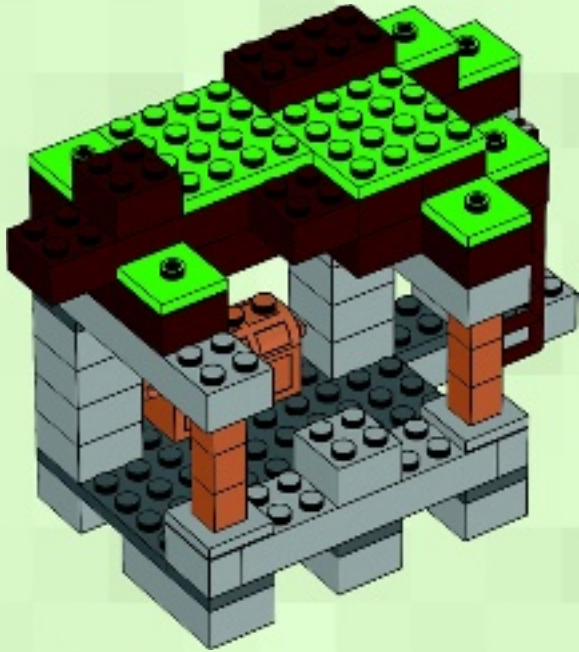

18

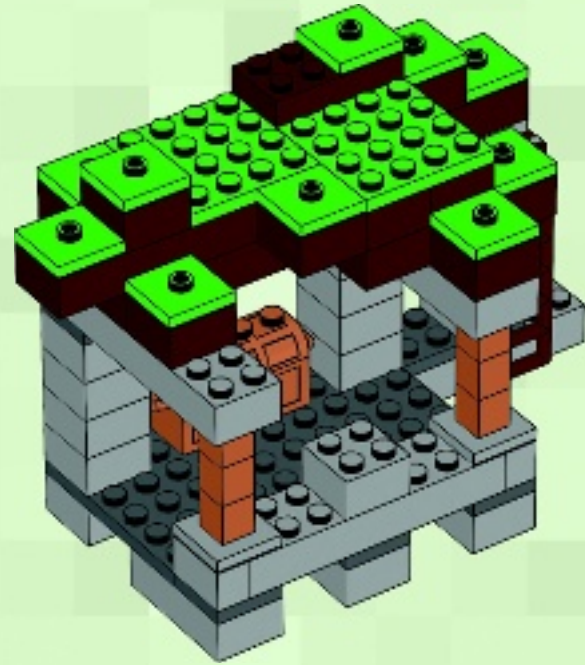



1



2



3

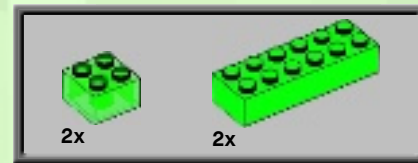

4

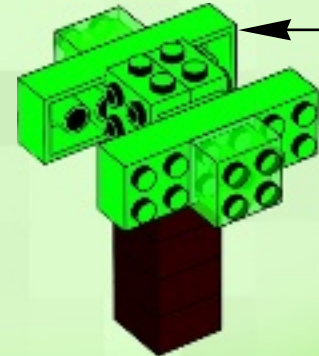
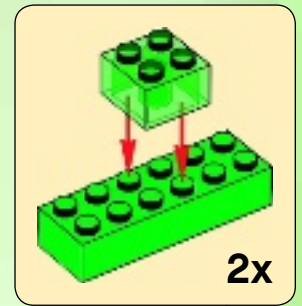



5

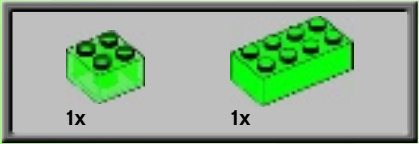
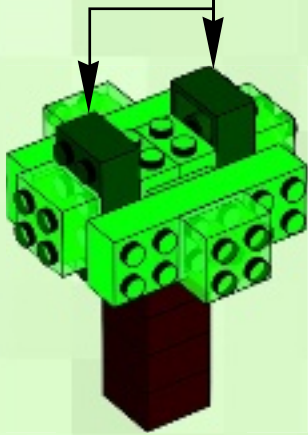
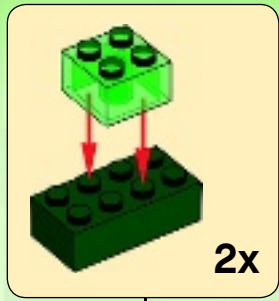

6

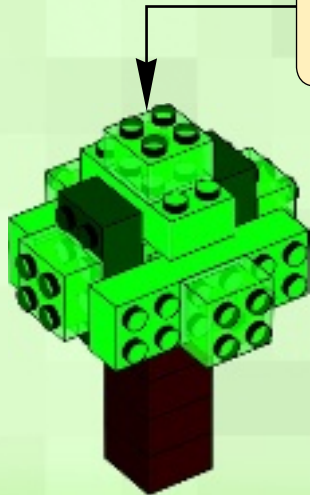
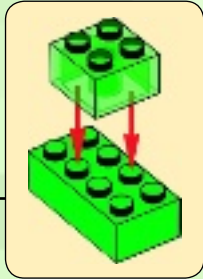

19

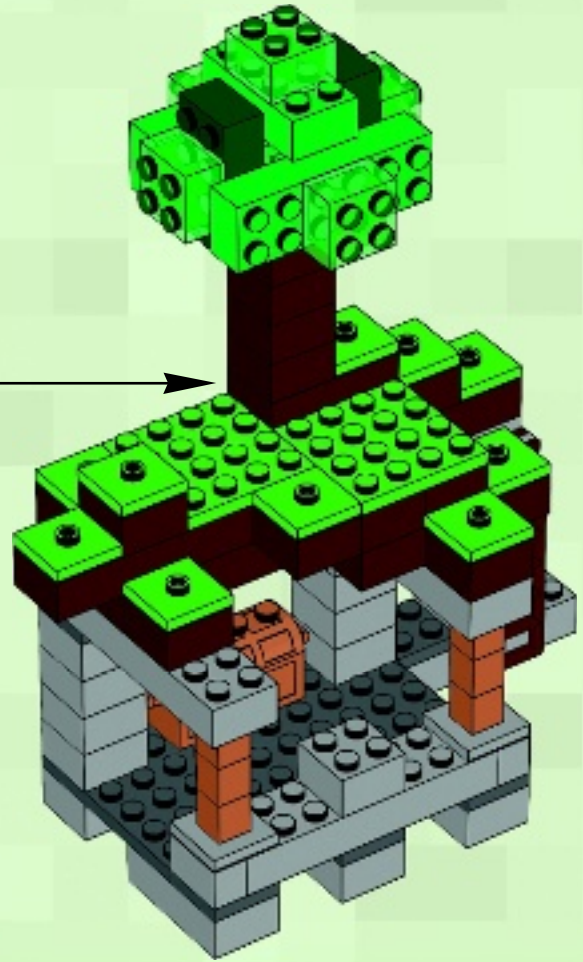

20

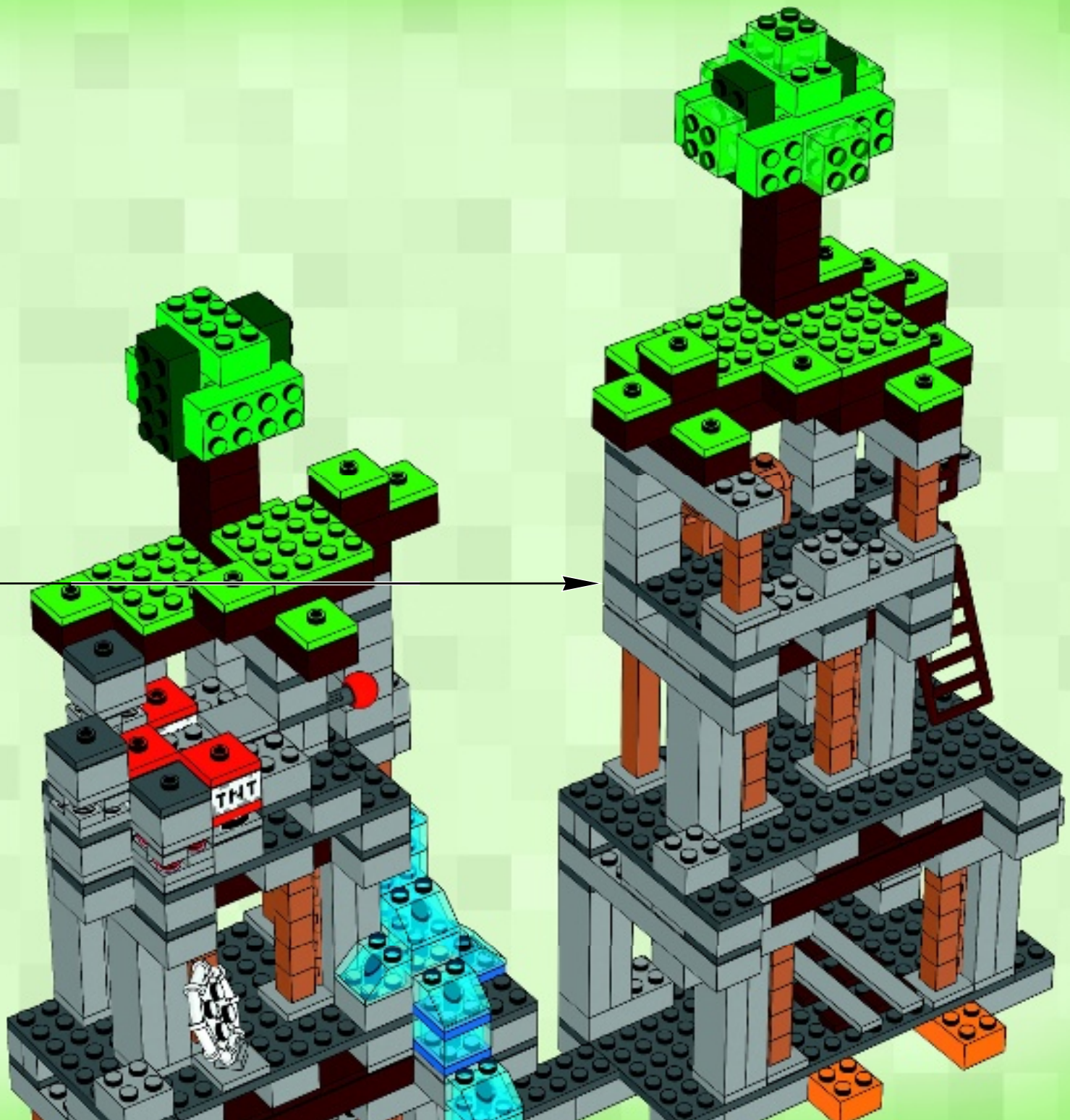

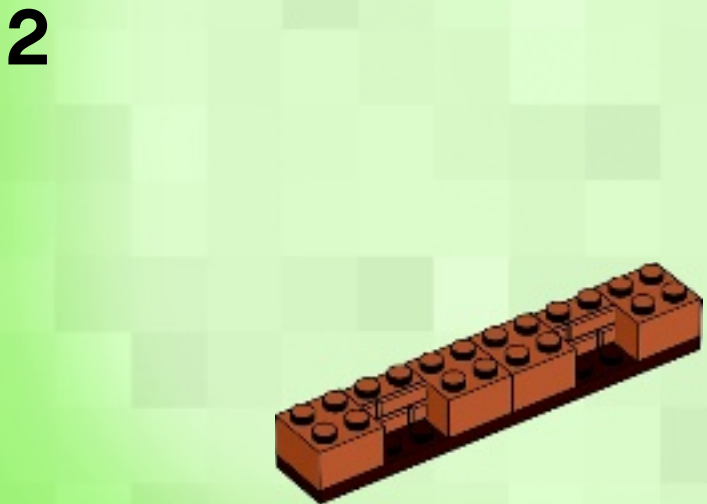
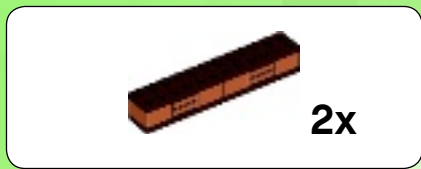

3

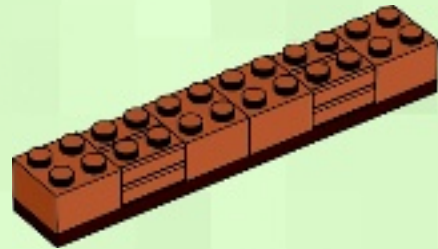

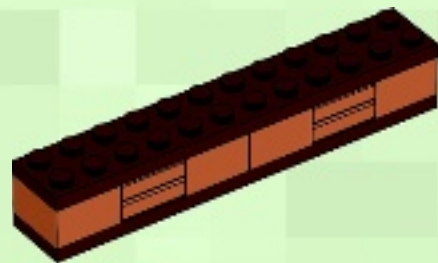

4



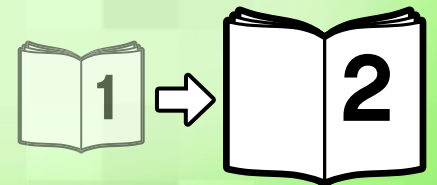
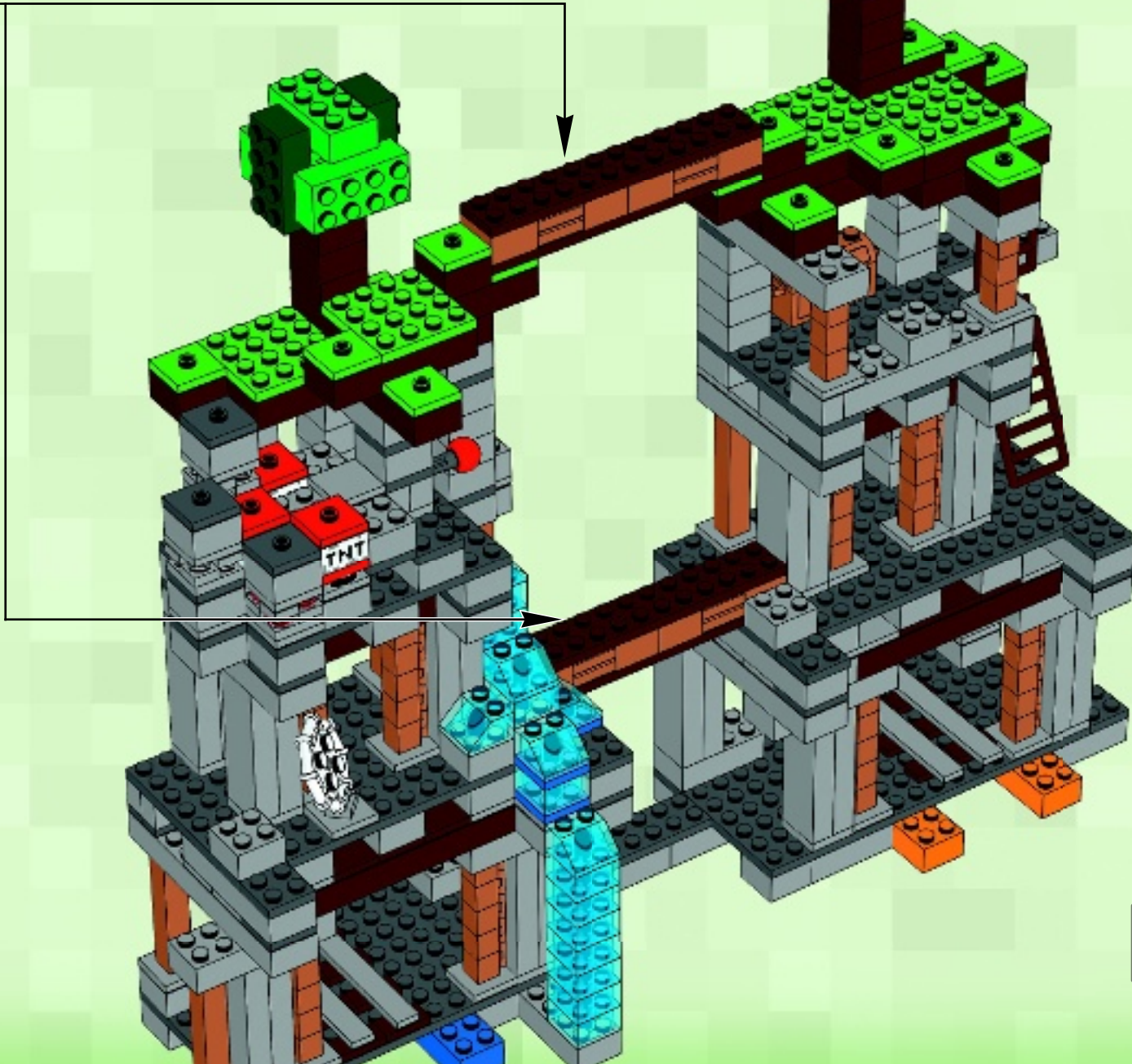

2x

21



 Minecraft is a sandbox construction game, inspired by Infiniminer, Dwarf Fortress and Dungeon Keeper, created by Markus Persson, the founder of Mojang AB. The game involves players creating and destroying various types of blocks in a three dimensional environment. The player takes an avatar that can destroy or create blocks, forming fantastic structures, creations and artwork across the various multi-player servers in multiple game modes.

 Minecraft est un jeu de construction « bac à sable » inspiré d'Infiniminer, Dwarf Fortress et Dungeon Keeper, créé par Markus Persson, le fondateur de Mojang AB. Dans ce jeu, les joueurs créent et détruisent divers types de blocs dans un environnement en trois dimensions. Le joueur incarne un avatar qui peut détruire ou créer des blocs, formant ainsi des structures, des créations et des images fantastiques au travers de divers serveurs multi-joueurs et dans des modes de jeu multiples.

 Minecraft es un juego de construcción libre creado por Markus Persson, fundador de Mojang AB, e inspirado en Infiniminer, Dwarf Fortress y Dungeon Keeper. A lo largo del juego, los jugadores crean y destruyen diferentes tipos de bloques dentro de un entorno tridimensional. A través de su personaje, cada jugador crea o destruye bloques con objeto de construir fantásticas estructuras, creaciones y obras artísticas en cualquiera de los diferentes servidores multijugador disponibles y los distintos modos que el juego pone a su alcance.

MINECRAFT[®]

